

catalogo
2018
luxury
operative
contract
wait
elements



ESSE SOLUTION_{SAGL}

FORNITURE AZIENDALI

Via Rompada, 37 - CASLANO

+41 076 758 5368 +41 079 709 8354

www.essesolution.ch info@essesolution.ch

catalogo
2018
luxury
operative
contract
wait
elements

6



3

showroom
showrooms
showrooms

Venezia,
Londra,
New York

112

paesi d'esportazione
export countries
pays d'exportation



49

modelli
designs
modèles



7

130.200

sedute/anno
chairs/year
sièges/an

4

certificazioni aziendali
quality certifications
certifications d'entreprise



270

finiture
finishes
finitions

→ p. 13 **luxury**

nordic → p. 16

x-chair → p. 24

olite → p. 34

celine → p. 40

sky soft → p. 48

sky ten → p. 48

sky mesh → p. 48

lex presidenziale → p. 58

andy → p. 62

sally → p. 66

rang → p. 68

→ p. 71 **operative**

tam → p. 74

loop → p. 82

lex → p. 88

zed → p. 100

flo → p. 106

five → p. 110

→ p. 113 **contract**

nordic → p. 116

nuvola → p. 122

people → p. 132

shock → p. 144

cocktail → p. 148

nesis → p. 152

nesis chic → p. 156

handle office → p. 160

block → p. 164

daisy → p. 168

only → p. 172

genesis → p. 176

mirò → p. 180

liliè → p. 190

tulip → p. 194

ellipse → p. 196

patch work → p. 200

adalia → p. 204

terre → p. 208

fungus → p. 212

→ p. 215 **wait**

colette → p. 218

voilà → p. 222

clark → p. 228

lois → p. 236

wendy → p. 242

dolly → p. 248

role → p. 254

blend → p. 258

venice → p. 262

time → p. 266

fuego → p. 268

→ p. 273 **elements**

→ p. 285 **finishes**

→ p. 294 **designers**

overview



luxury



nordic
p. 16



x-chair
p. 24



olite
p. 34



celine
p. 40



sky soft
p. 48



sky ten
p. 48



sky mesh
p. 48



lex presidenziale
p. 58



andy
p. 62



sally
p. 66



rang
p. 68



operative



tam
p. 74



loop
p. 82



lex
p. 88



zed
p. 100



flo
p. 106



five
p. 110



contract



nordic
p. 116



nuvola
p. 122



people
p. 132



shock
p. 144



cocktail
p. 148



nesis
p. 152



nesis chic
p. 156



handle office
p. 160



block
p. 164



daisy
p. 168



only
p. 172



genesis
p. 176



mirò
p. 180



liliè
p. 190



tulip
p. 194



ellipse
p. 196



patch work
p. 200



adalia
p. 204



terre
p. 208



fungus
p. 212



wait



colette
p. 218



voilà
p. 222



clark
p. 228



lois
p. 236



wendy
p. 242



dolly
p. 248



role
p. 254



blend
p. 258



venice
p. 262



time
p. 266



fuego
p. 268

luxury

ESSE SOLUTION S.p.A.

FORNITURE AZIENDALI

Via Rompeda, 37 - CASLAND

+41 076 798 5368 +41 079 709 8354

www.essesolution.ch info@essesolution.ch

luxury



nordic
p. 16



x-chair
p. 24



olite
p. 34



celine
p. 40



sky soft
p. 48



sky ten
p. 48



sky mesh
p. 48



lex presidenziale
p. 58



andy
p. 62



sally
p. 66



rang
p. 68

poltrone direzionali

Serie di poltrone direzionali che arredano con stile i diversi ambienti ufficio, da quelli contemporanei a quelli più classici. L'ampia gamma di proposte consente di spaziare tra i modelli dalle forme ad alto contenuto tecnico-ergonomico a quelle più tradizionali, dotate di dettagli e finiture che le rendono attuali. Il disegno e la qualità dei materiali impiegati esalta la lavorazione artigianale made in Italy.

executive chairs

A series of executive chairs that will bring style to the furnishings of different office environments, from contemporary to traditional. The wide range of options includes models offering high technical and ergonomic performance to more traditional designs with details and finishes that make them more contemporary. The design and the quality of the materials used showcases the finest Italian craftsmanship.

fauteuils de direction

Cette série de fauteuils de direction meuble avec style les différents espaces du bureau, du plus moderne au plus classique. Une vaste gamme qui s'étend des modèles aux formes hautement techniques et ergonomiques à d'autres, plus traditionnelles, aux détails et finitions qui les rendent très actuels. Le design et la qualité des matériaux utilisés met en valeur la réalisation artisanale 100% italienne.

designers

Baldanzi & Novelli
Alessandro Crosera
R&D Milani

nordic

16



designer

Baldanzi & Novelli

it Una collezione di poltrone presidenziali – ergonomiche e leggere – dal caratteristico sedile curvo, declinata anche nella versione contract con panche, poltrone e divani. La seduta rivestita in pelle o tessuto, in un'ampia gamma di colori, è disponibile in tre diverse altezze. Il meccanismo sincronizzato può essere incorporato nella scocca.

en A collection of executive chairs – ergonomic and light – with a characteristic curved seat, also available in contract version with benches, armchairs and sofas. The armchair, which comes in leather or fabric and in a wide range of colours, is available in three different backrest heights. A synchronised tilt mechanism can be incorporated into the frame.

fr Cette collection de fauteuils président, légers et ergonomiques, affiche une caractéristique assise courbe et se décline également en version détente, avec des banquettes, des fauteuils et des canapés. Le fauteuil, revêtu en cuir ou en tissu, est disponible dans une large gamme de coloris et dans trois différentes hauteurs de dossier. Le mécanisme synchrone peut être intégré à la structure.





finishes

1. WM 0101 / 2. WM 0142 + Rubelli
Cortez 0013 / 3. WM 0112





finishes

1. WM 0142 + Rubelli Cortez 0013 /
 2. WM 0101 / 3-4. WM 0102
-





finishes

Kvadrat Remix 2 0722 +

Kvadrat Remix 2 0612





finishes

1. SK 0229 / 2. LN 3364

x-chair

24



designer

R&D Milani

it Poltrona dalle grandi qualità ergonomiche e molteplici dettagli tecnici per la massima personalizzazione. Proposta con schienale in rete nera, inserti in alluminio lucido e traslatore di seduta, con o senza poggiatesta. Il supporto lombare è regolabile in altezza e profondità, i braccioli sono regolabili in 3D.

en A high-performance ergonomic chair with multiple technical features to give the ultimate in customisability. Available with a black mesh backrest, polished aluminium inserts and sliding seat adjustment, with or without headrest. The lumbar support is height and depth-adjustable, and the armrests are 3D adjustable.

fr Fauteuil aux grandes qualités ergonomiques et aux nombreux détails techniques, pour une personnalisation extrême. Il possède un dossier en résille noire, des inserts en aluminium poli et le système de translation d'assise, avec ou sans appuie-tête. Le soutien lombaire est réglable en hauteur et en profondeur, et les accoudoirs sont réglables en trois dimensions.



finishes

1. LN 2500 / 2. LN 2535

**Ogni passaggio del
processo produttivo
viene eseguito
manualmente
da artigiani esperti,
capaci di creare
bellezza, eleganza
e funzionalità.**

**Each step in the production process
is carried out by hand, by skilled
craftsmen able to shape beautiful,
elegant, functional items.**

**Chaque étape de la production est
effectuée à la main, par des artisans
experts et en mesure de créer
élégance, beauté et fonctionnalité.**







finishes

1. LN 0443 / 2. LN 2527 / 3. LN 3348



it X-chair operativa,
caratteristiche tecniche.
en Operator X-chair,
technical characteristics.
fr Siège de travail X-chair,
caractéristiques techniques.

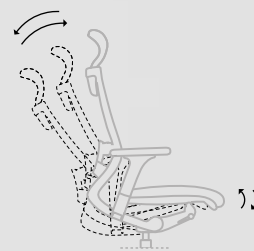

it Poggiatesta regolabile
in altezza e orientamento.
en Height and orientation
adjustable padded headrest.
fr Appuie-tête réglable
en hauteur et orientable.



it Supporto lombare regolabile
in altezza e in profondità.
en Height and depth
adjustable lumbar support.
fr Soutien lombaire réglable
en hauteur et profondeur.



it Traslatore di seduta.
en Sliding seat.
fr Translation d'assise.



it Meccanismo sincronizzato
con tre limitazioni di corsa
e regolazione laterale.
en Synchronized mechanism
with three limitation tilt positions
and side tension.
fr Mécanisme synchrone avec
trois limitations de basculement
et régulation latérale.

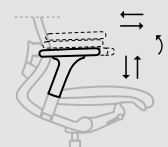

it Braccioli regolabili in
3D con pads in PU morbido.
en 3D adjustable armrests
with soft PU pads.
fr Accoudoirs réglables en 3D
avec manchettes en PU souple.

it Sedile in schiumato amovibile.
en Removable injected
foam seat pad.
fr Assise amovibile
en mousse injectée.



it Regolazione
positiva del sedile.
en Positive tilt action.
fr Régulation
positive de l'assise.

finishes
CX 0031





finishes
LN 2500





finishes

1. MA 0304 / 2. LN 2500

**Le nostre mani
sono il principale
strumento di lavoro.
Rivelano abilità,
precisione, attenzione
e sensibilità estetica.**

**Our main tool is our hands, which
reveal skill, precision, attention
and an eye for style and beauty.**

**Nos mains sont notre principal
outil de travail. Elles révèlent
l'habileté, la précision, l'attention
et la sensibilité esthétique.**



olite

34

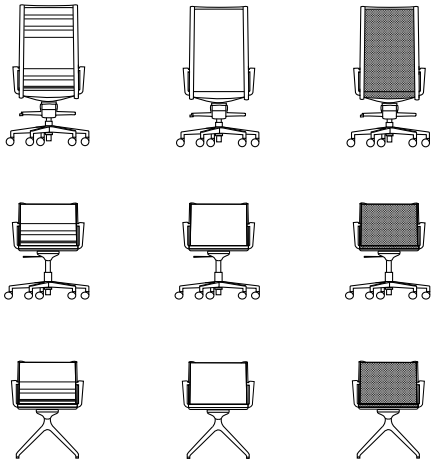

designer

R&D Milani

it Dalla perfetta combinazione tra comfort e funzionalità nasce Olite. Con rivestimento in rete traspirante e lavabile, in pelle o in tessuto autoportante, è possibile scegliere tra una struttura in alluminio lucido o alluminio verniciato nero opaco.

en Olite is the perfect combination of comfort and functionality. It can be upholstered in breathable, washable mesh, in leather or in tensile fabric, while the frame comes in polished aluminium or matt black painted aluminium.

fr Olite naît d'une union parfaite entre confort et fonctionnalité. Avec son revêtement en résille respirant et lavable, en cuir ou en tissu autoportant, vous pourrez choisir entre une structure en aluminium poli ou en aluminium verni noir mat.



finishes
KT 0060





finishes
CM 0900



finishes
1. KT 0060



finishes

2-3. LN 2511

celine

40

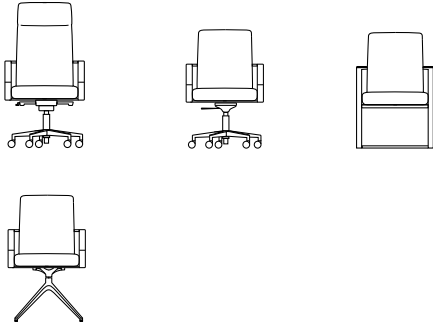

designer
R&D Milani

it Comoda poltrona dallo stile ricercato. Lo schienale è proposto in versione imbottita liscia o con lavorazione plissettata. I braccioli in alluminio lucido con rivestimento permettono il movimento di oscillazione sincronizzata.

en A comfortable, stylish chair. The backrest is available in smooth padding or with a pleated finish. The polished aluminium armrests with upholstered pads allow the chair's synchronized movement.

fr Fauteuil confortable au style recherché. Son dossier est disponible en version rembourrée lisse ou plissée. Les accoudoirs en aluminium poli revêtus permettent de déclencher le mouvement d'oscillation synchrone.





finishes

1-2. RC 6501 / 3. SK 0855





finishes

1. LN 2523 / 2-3. LN 5432



it_Celine, caratteristiche tecniche.
en_Celine, technical characteristics.
fr_Celine, caractéristiques techniques.

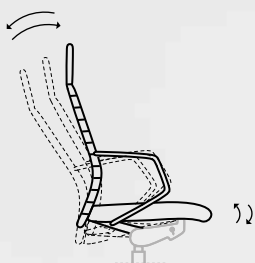

it_Meccanismo sincronizzato con cinque posizioni di blocco e regolazione laterale.
en_Five locking positions synchronized mechanism with side tension control.
fr_Mécanisme synchrone avec cinq positions de blocage et régulation latérale.

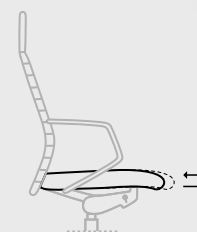

it_Traslatore di seduta.
en_Sliding seat.
fr_Translation d'assise.

finishes

1. RC 6501 / 2. SK 0855





finishes

1. ZS 02E8 / 2. TA 1150 / 3. SK 0855

sky soft, sky ten, sky mesh

48

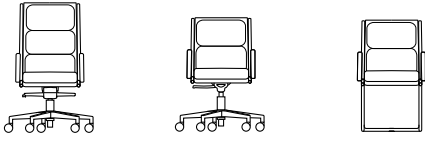

A. Sky soft



B. Sky ten

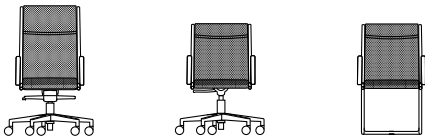

C. Sky mesh

designer
R&D Milani

it La linea sinuosa della struttura portante cromata, priva di viti laterali, caratterizza la collezione. Le sedute sono proposte nella versione a rete, imbottita con cuciture orizzontali o con morbidi cuscini. Lo schienale può essere alto o medio e con base a slitta.

en The sinuous lines of the chrome framework, with no side frame screws, define this collection. These chairs are available in a mesh version, padded version with horizontal stitching, or with soft cushions. The backrest can be high or medium and with cantilever base.

fr La ligne sinueuse de la structure chromée, sans vis latérales, caractérise cette collection. Ces sièges sont disponibles dans une version résille, rembourrée à coutures horizontales, ou à coussins. Le dossier peut être haut ou bas et à piètement luge.



finishes sky ten
MA 0706

luxury – sky soft, sky ten, sky mesh





finishes sky mesh

1-2. RT 0014 / 3-4. RT 0015



finishes sky mesh, sky ten, sky soft

1. RT 0024 / 2. ML 0002 / 3. CX 0880

it_Profilii cromati senza viteria.
en_Screwless side frame.
fr_Profils chromés sans vis.

53



finishes sky ten
4. MA 0706

luxury – sky soft, sky ten, sky mesh





finishes sky soft

1. TA 1850 / 2-3. CX 0012





luxury – sky soft, sky ten, sky mesh



finishes sky ten

1-2. RC 4504 / 3. RC 6508 / 4. MA 0706

**In ogni nuovo
progetto studiamo
e scegliamo i tessuti
e le pelli migliori
per vestire le nostre
sedie e poltrone.**

**For each new project, we study and
select the finest fabrics and leathers
to adorn our chairs and armchairs.**

**Pour chaque nouveau projet, nous
étudions et choisissons les meilleurs
tissus et les meilleurs cuirs pour
revêtir nos chaises et fauteuils.**



lex presidenziale

58

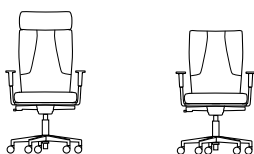
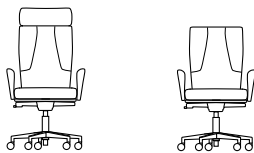

designer
R&D Milani

it Sedute manageriali eleganti e moderne, declinate anche nella versione operativa. Il modello presidenziale e direzionale è proposto con schienale imbottito e retro rivestito. Anche il poggiatesta e i braccioli possono essere completamente rivestiti.

en Elegant, modern managerial chairs, also available in operative version. The high back and medium back are available with padded backrest and upholstered back. Both the headrest and the armrests can be fully upholstered.

fr Des fauteuils de direction élégants et modernes, également déclinés en version siège de travail. Les modèles président et de direction sont proposés avec dossier rembourré et arrière revêtu. L'appuie-tête et les accoudoirs peuvent aussi être entièrement revêtus.



finishes
LN 3396



finishes

1. LN 2523 / 2. LN 2523 + Kvadrat
Remix 2 0123 / 3. TA 0650 / 4. LN 3396



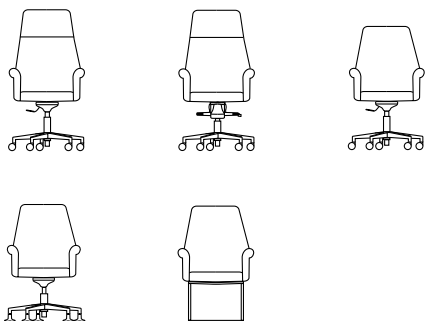

designer

Alessandro Crosera

it Poltrona dedicata agli ambienti ufficio classici e importanti. I braccioli formano un tutt'uno con la seduta. La cucitura a croce, opzionale, dona ulteriore pregio al modello.

en A chair specifically designed for traditional, imposing offices. The armrests form a complete unit with the seat. Optional cross-stitching lends the model extra prestige.

fr Fauteuil conçu pour les espaces de bureau classiques et d'envergure. Les accoudoirs ne font qu'un avec le siège. La couture croisée, en option, donne une touche raffinée au modèle.



finishes

1. LN 2200 / 2. LN 0443



finishes

1-2. LN 3348 + RC 8501 / 3. LN 0443



it_Optionale: cucitura a croce.
en_Optional: cross-stitch detailing.
fr_Option : couture croisée.

**L'esperienza costruita
nel tempo ci consente
di essere estremamente
creativi, di affrontare con
flessibilità ogni progetto
e dare vita a nuovi linguaggi.**

**The experience we have built
up over the years has allowed
us to be extremely creative,
to adopt a flexible approach
to each project, and to create
new forms of expression.**

**L'expérience acquise au fil du
temps nous permet une créativité
infinie, de voir le défi d'un nouveau
projet avec flexibilité et de donner
vie à de nouveaux langages.**



sally

66

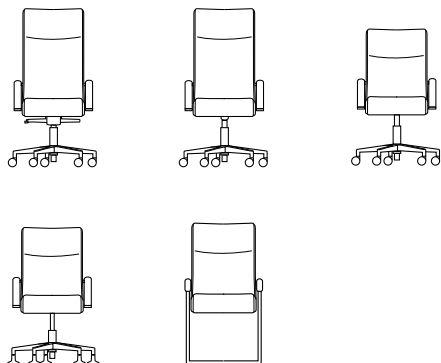

designer
R&D Milani

it Poltrona classica dalle dimensioni generose e grande comfort. È disponibile con schienale alto, medio e nella versione visitatore a slitta.

I braccioli sono completamente rivestiti.

en Classic seat offering generous dimensions and outstanding comfort. Available in high-back and medium-back versions and cantilever visitor version. The armrests are fully upholstered.

fr Fauteuil classique qui allie belles dimensions et grand confort. Disponible avec dossier haut, moyen et à piétement luge dans la version visiteur. Les accoudoirs sont complètement revêtus.





finishes

1. SK 0855 / 2. SK 0855 / 3. LN 2523

rang

68

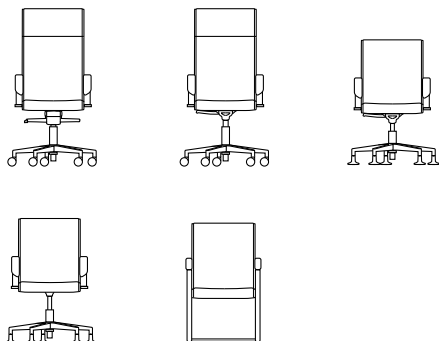

designer
R&D Milani

it Seduta caratterizzata da una sottile imbottitura ad alta densità. Disponibile nella versione presidenziale, direzionale e visitatore con braccioli costituiti da una struttura in acciaio rivestita.

en A seat distinguished by its thin, high-density padding. Available in presidential, executive and visitor versions with upholstered steel armrests.

fr Siège caractérisé par un rembourrage fin et à haute densité. Disponible en version président, direction et visiteur avec des accoudoirs en acier revêtu.





finishes

1. ZS 06ME / 2. ZS 05L1 / 3. ZS 04L1



ESSE SOLUTION_{S.A.G.L.}

FORNITURE AZIENDALI

Via Rompada, 37 - CASLANO

+41 076 758 5368 +41 079 709 8354

www.essesolution.ch info@essesolution.ch

operative

operative



tam
p. 74



loop
p. 82



lex
p. 88



zed
p. 100



flo
p. 106



five
p. 110

sedute operative

Una collezione di comode sedute, versatili e innovative. Le caratteristiche ergonomiche sono certificate dai numerosi standard internazionali. Le molteplici opzioni funzionali consentono di assecondare le diverse esigenze per una postazione lavorativa personalizzata.

operator seating

A collection of innovative chairs designed for comfort and versatility. The ergonomic features of this collection meet a number of international quality standards. The numerous optional features allow individual needs to be met, giving a personalised work station.

sièges de travail

Une collection de sièges confortables, polyvalents et innovants. Leurs caractéristiques ergonomiques sont certifiées par de nombreuses normes internationales. Les multiples options fonctionnelles permettent de répondre à différents besoins, pour un poste de travail personnalisé.

designers

Massimo Costaglia
Giulio Mazzanti
R&D Milani

tam

74



designer

Massimo Costaglia

it Sistema di sedute operative, ergonomiche e confortevoli, perfette per arredare anche gli ambienti direzionali. Sono disponibili nella versione con schienale in rete o imbottite, con appoggio lombare interno regolabile.

en A collection of ergonomic, comfortable office chairs, perfect even for the boardroom. Available in versions with mesh or padded backrest, with adjustable internal lumbar support.

fr Gamme de sièges de travail ergonomiques et confortables, parfaits pour aménager les bureaux de direction. Disponibles dans la version à dossier en résille ou rembourré, avec soutien lombaire réglable intégré.





finishes
GO 0033 + CX 0925



finishes

1-4. GO 0089 + TA 1850 / 5. CX 0120

it Tam schienale imbottito,
caratteristiche tecniche.
en Tam padded backrest,
technical characteristics.
fr Tam dossier capitonné,
caractéristiques techniques.

it Sedile e schienale
in schiumato ad alta densità.
en High density injected
foam seat and backrest pad.
fr Assise et dossier en
mousse injectée haute densité.



it Supporto lombare
interno regolabile in altezza.
en Height adjustable
inner lumbar support.
fr Soutien lombaire interne
réglable en hauteur.



it Traslatore di seduta.
en Sliding seat.
fr Translation d'assise.

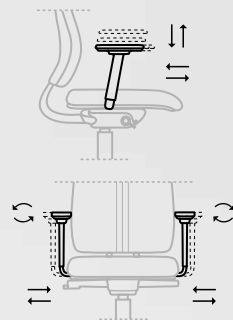

it Scelta di braccioli
regolabili 1D, 2D e 4D.
en Choice of 1D, 2D and
4D adjustable armrests.
fr Choix d'accoudoirs
réglables 1D, 2D ou 4D.



it Meccanismo sincronizzato
con cinque posizioni di blocco
e regolazione laterale.
en Five locking positions
synchronized mechanism
with side tension control.
fr Mécanisme synchrone
avec cinq positions de
blocage et régulation latérale.



finishes
1. CX 0120





finishes

2-3. CX 0120 / 4. LN 2523





finishes

1. LN 1000 / 2. GO 0033 + TA 1850

loop

82

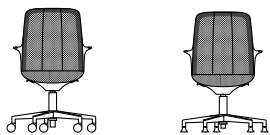

designer

Massimo Costaglia & Giulio Mazzanti

it Seduta meeting dal profilo nitido e armonico, sottile ed elegante.

La struttura in plastica – rivestita in rete o in tessuto portante – e il meccanismo oscillante garantiscono livelli di comfort ottimali.

en Subtle, elegant meeting chairs with a clean, harmonious profile.

The plastic structure – upholstered in mesh or in tensile fabric – and the tilt mechanism guarantees the highest levels of comfort.

fr Siège de réunion à la ligne essentielle et harmonieuse, fine et élégante. Sa structure en plastique, revêtue de résille ou de tissu autoportant, et le mécanisme basculant offrent un confort optimal.





finishes
CM 0900





finishes

1-2. KT 0090 / 3. KT 0021



finishes
CM 0090

it_Loop rete,
caratteristiche tecniche.
en_Loop mesh chair,
technical characteristics.
fr_Loop résille,
caractéristiques techniques.

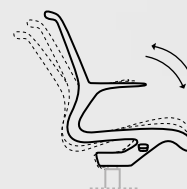

it_Meccanismo oscillante.
en_Tilting mechanism.
fr_Mécanisme basculant.

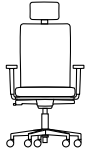

A.

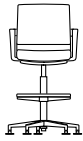

B.



C.

designer

R&D Milani

it Famiglia di sedute operative e funzionali. Sono disponibili in molteplici varianti e in un'ampia gamma di combinazioni: con scocca e braccioli in plastica bianca o nera, schienale imbottito o in rete e poggiatesta regolabile rivestito. Le basi possono essere in alluminio o in nylon nero.

en A family of functional office chairs. Available in various options and in a wide range of combinations: with body and arms in white or black plastic, padded or mesh backrest and adjustable padded headrest. The bases come in aluminium or nylon.

fr Une gamme de sièges de travail fonctionnels. Disponibles dans de nombreuses variantes et dans une vaste gamme de combinaisons : avec structure et accoudoirs en plastique blanc ou noir, dossier rembourré ou en résille et appuie-tête réglable revêtu. Les bases peuvent être en aluminium ou en nylon noir.



finishes
GO 0033 + RC 8030

it_Operative
en_Operative
fr_Operative

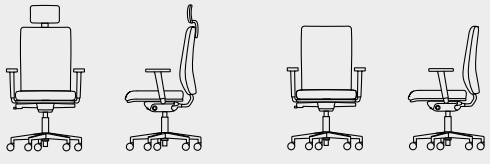

A.1-2

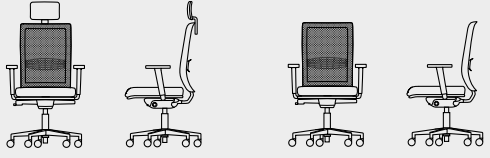

A.3-4

it_Sgabello
en_Stool
fr_Tabouret

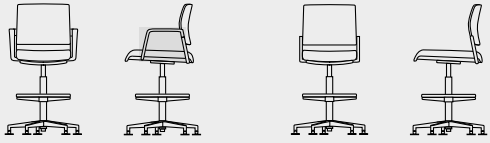

B.1-2

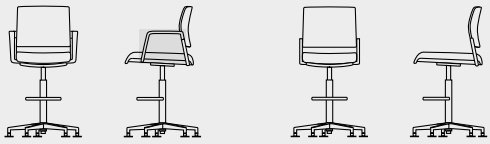

B.3-4

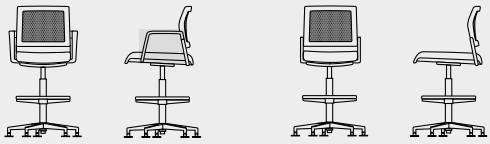

B.5-6

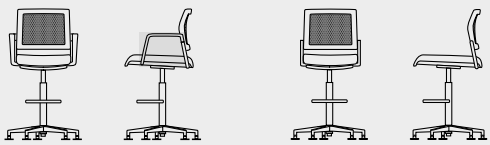

B.7-8

it_Visitatore
en_Visitor
fr_Visiteur



C.1-2



C.3-4

it_Visitatore
en_Visitor
fr_Visiteur



C.5-6



C.7-8



C.9-10



C.11-12





finishes

1. GO 0089 + NE 0015 / 2. GO 0089 +
NE 0573 / 3. NE 0533 / 4. NE 0333



finishes

1. GO 0033 + RC 8030 /
 2. GO 0043 + LN 2523
-

it Lex operativa rete,
caratteristiche tecniche.
en Lex operative mesh,
technical characteristics.
fr Lex opérative maille,
caractéristiques techniques.

93



it Poggiatesta regolabile
in altezza e orientamento.
en Height and orientation
adjustable padded headrest.
fr Appui-tête réglable en
hauteur et orientable.

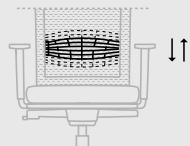

it Supporto lombare
regolabile in altezza.
en Height adjustable
lumbar support.
fr Soutien lombaire
réglable en hauteur.

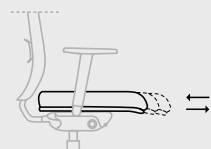

it Traslatore di seduta.
en Sliding seat.
fr Translation d'assise.

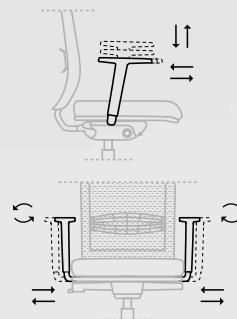

it Scelta di braccioli
regolabili 1D, 2D e 4D.
en Choice of 1D, 2D and
4D adjustable armrests.
fr Choix d'accoudoirs
réglables 1D, 2D ou 4D.

it Sedile in schiumato
ad alta densità.
en High density
injected foam seat pad.
fr Assise en mousse
injectée haute densité.

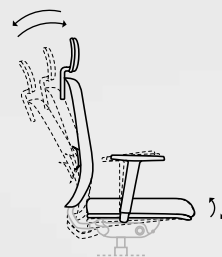

it Meccanismo sincronizzato
con cinque posizioni di
blocco e regolazione laterale.
en Five locking positions
synchronized mechanism
with side tension control.
fr Mécanisme synchrone
avec cinq positions de
blocage et régulation latérale.



finishes

1. Kvadrat Remix 2 0973 /
 2. GO 0043 + TF 0018
-



finishes

3. NE 0119 / 4. GO 0001 + NE 0572



finishes

1. RC 6501 / 2. RC 6508 / 3-4. RC 7504



**Dal disegno del cartamodello
alla scelta dei tessuti,
dal montaggio
al controllo qualità,
conosciamo e seguiamo
con attenzione ogni passaggio
del processo produttivo.**

**From the drawing of the paper
pattern and the choice of the fabrics,
through to assembly and quality
control, we take care of every step
in the production process.**

**Du dessin du patron au choix
des tissus, du montage au contrôle
qualité, nous connaissons par cœur
et respectons attentivement chaque
étape de production.**





finishes

1. GO 0033 + TA 2550 / 2. RC 6508 /
3. RC 7503
-



finishes

4. RC 7503 / 5. GO 0001 + TA 1850 /
6. RC 3508

zed

100

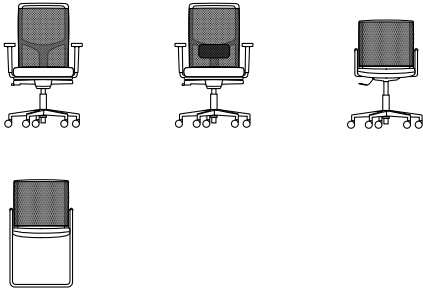

designer
R&D Milani

it I diversi aspetti tecnici sono stati studiati per conferire maggiore ergonomia e solidità al modello. Lo schienale in rete, disponibile in otto colori, è indipendente e regolabile in altezza. Su richiesta viene inserito il supporto lombare. La versione visitatore viene presentata con slitta cromata impilabile.

en The various technical features of this model have been designed to offer the best possible strength and ergonomic performance. The mesh backrest can be a separate colour, with eight to choose from, and is height adjustable. Lumbar support can be included on request. The visitor version comes with a stackable chromed cantilever base.

fr Les différents aspects techniques ont été étudiés pour accroître la solidité et l'ergonomie de ce modèle. Le dossier en résille, disponible en huit coloris, est indépendant et réglable en hauteur. Le soutien lombaire peut être intégré sur demande. La version visiteur présente un piétement luge chromé empilable.





finishes
RT 0015 + ML 0014





finishes

1. RT 0014 + RC 8501 / 2. RT 0015 +
ZS 02F1 / 3. RT 0014 + RC 8501



finishes

1. RT 0015 + ML 0014 /
 2. RT 0024 + CX 0880
-

it_Zed operativa,
caratteristiche tecniche.
en_Zed operative,
technical characteristics.
fr_Siège de travail Zed,
caractéristiques techniques.

105



it_Schienale regolabile in altezza.
en_Height-adjustable backrest.
fr_Dossier réglable en hauteur.



it_Supporto lombare regolabile in profondità.
en_Depth-adjustable lumbar support.
fr_Soutien lombaire réglable en profondeur.

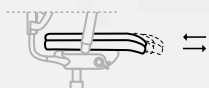

it_Traslatore di seduta.
en_Sliding seat.
fr_Translation d'assise.

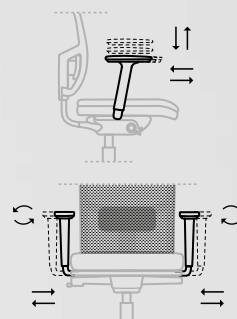

it_Scelta di braccioli regolabili 1D, 2D e 4D.
en_Choice of 1D, 2D and 4D adjustable armrests.
fr_Choix d'accoudoirs réglables 1D, 2D ou 4D.

it_Sedile in schiumato ad alta densità.
en_High density injected foam seat pad.
fr_Assise en mousse injectée haute densité.



it_Meccanismo sincronizzato con cinque posizioni di blocco e regolazione laterale.
en_Five locking positions synchronized mechanism with side tension control.
fr_Mécanisme synchrone avec cinq positions de blocage et régulation latérale.

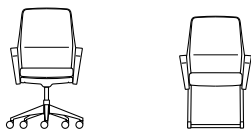

designer

R&D Milani

it Un design essenziale e leggero caratterizza questa poltroncina operativa. Con meccanismo sincronizzato e struttura in plastiche bianche, ha lo schienale in rete e i braccioli fissi. La versione visitatore ha la base a slitta.

en A light, simple design distinguishes this office chair. With synchronized mechanism and a white plastic frame, it comes with a mesh backrest and fixed armrests. The visitor version comes with a cantilever base.

fr Ce fauteuil de travail se distingue par son design épuré et léger. Doté d'un mécanisme synchrone et d'une structure en plastique blanc, son dossier est en résille et ses accoudoirs sont fixes. Version visiteur à piètement luge disponible.



finishes
GO 0001 + TA 1150

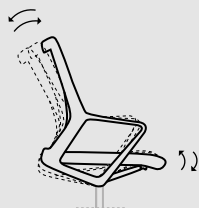

it_ Meccanismo sincronizzato
bloccabile in posizione di lavoro.
en_ Synchronized mechanism
with work lock position.
fr_ Mécanisme synchrone
bloccable en position de travail.



it_ Traslatore di seduta.
en_ Sliding seat.
fr_ Translation d'assise.





finishes

1. GO 0001 + TA 1150 /
 2. GO 0043 + MA 0803
-

five

110



designer
R&D Milani

it Five è una poltroncina operativa con meccanismo sincronizzato. Con schienale alto e braccioli regolabili in altezza, la base può essere in nylon o in alluminio lucido.

en Five is an office chair with synchronized mechanism. It has a high back and height-adjustable arms, while the base comes in nylon or in polished aluminium.

fr Five est un fauteuil de travail à mécanisme synchrone. Muni d'un dossier haut et d'accoudoirs réglables en hauteur, son piétement est disponible en nylon ou en aluminium poli.



finishes

1. NE 0572 / 2. NE 0119



ESSE SOLUTION_{S.A.G.L.}
FORNITURE AZIENDALI
Via Rompada, 37 - CASLANO
+41 076 758 5368 +41 079 709 8354
www.essesolution.ch info@essesolution.ch

contract

contract

114



nordic
p. 116



nuvola
p. 122



people
p. 132



shock
p. 144



cocktail
p. 148



nesis
p. 152



nesis chic
p. 156

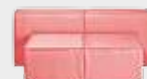

handle office
p. 160



block
p. 164



daisy
p. 168



only
p. 172



genesis
p. 176



mirò
p. 180



liliè
p. 190



tulip
p. 194



ellipse
p. 196



patch work
p. 200



adalia
p. 204



terre
p. 208



fungus
p. 212

divani e sedute attesa

In equilibrio tra design e comfort, le poltroncine e i divani sono ideati per sale d'attesa, bar, ristoranti e hotel. Dalla scelta dei materiali al disegno delle forme, morbide e avvolgenti, ogni modello è studiato con cura e nel dettaglio, in linea con il concetto di break out area, spazio che oggi riveste una grande importanza nel mondo dell'ufficio.

waiting area sofas and seating

Bringing together design and comfort, our armchairs and sofas are designed for waiting rooms, bars, restaurants and hotels. From the choice of materials to the soft, welcoming shapes, each model is designed with care and attention to convey the concept of a break out area, a space of great importance in today's offices.

canapés et fauteuils

Dans un équilibre entre design et confort, les fauteuils et canapés proposés sont pensés pour les salles d'attente, les cafés, les restaurants et les hôtels. Du choix des matériaux au design des formes, douces et enveloppantes, chaque modèle est étudié dans le moindre détail, en ligne avec l'idée d'espace de détente qui prend de plus en plus de place dans l'entreprise.

designers

Baldanzi & Novelli
C/B Design
Alessandro Crosera
Orlandini Design
R&D Milani

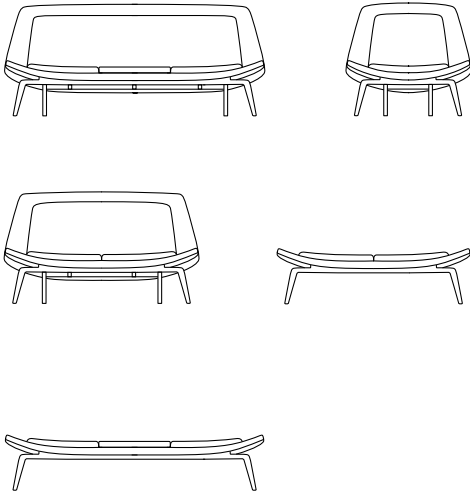

designer

Baldanzi & Novelli

it Collezione di poltroncine, divani e panche dalle linee flessuose dedicate all'attesa. Il telaio in legno e lo schienale con imbottitura doppia, realizzabile in un'ampia gamma di tessuti, conferiscono ai modelli un aspetto evocativo e contemporaneo. La cucitura può essere a doppia ribattitura o a croce.

en A collection of armchairs, sofas and benches with soft lines for a comfortable wait. The wooden frame and the double-padded backrest, available in a wide range of fabrics, give these models an appealing, contemporary look. Choose from a double-stitched or cross-stitched finish.

fr Collection de fauteuils, de canapés et de banquettes aux lignes ondoyantes conçues pour les salles d'attente. Le châssis en bois et le dossier à double rembourrage, disponible dans une vaste gamme de tissus, confèrent aux modèles un aspect contemporain et très esthétique. La couture peut être croisée ou à double surpiqûre.

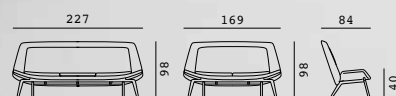
**finishes**

1. WM 0102 / 2. WM 0133









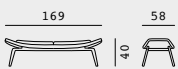
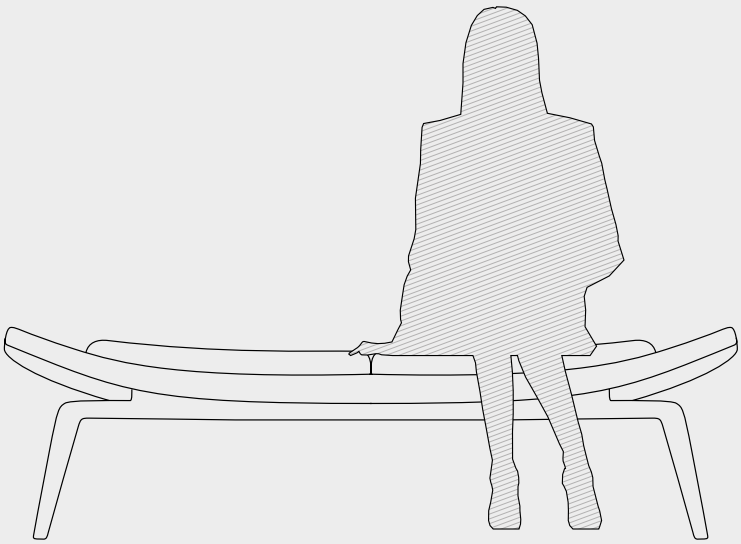

finishes

CX 0013

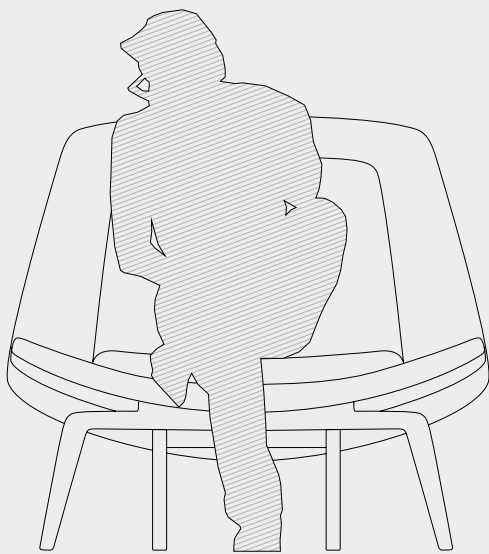

106

84



98



40

finishes

Remix 2 0612

nuvola

122

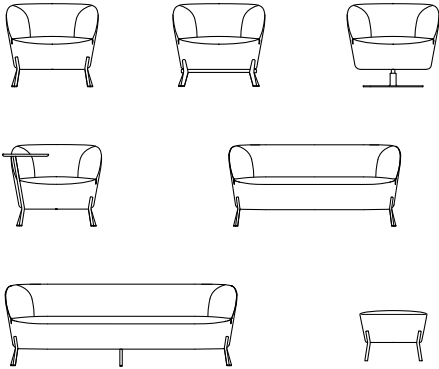

designer

C/B Design

it Nuvola è un morbido monolite che trasmette una sensazione di calore e benessere all'ambiente in cui viene inserito. I diversi modelli sono disponibili con gambe cromate, in legno o con colonna girevole. Alla struttura può inoltre essere applicato un tavolino orientabile.

en Nuvola is a soft monolite that transmits a sense of warmth and wellbeing to any setting. The different models are available with chrome or wooden legs or swivel column base. A small adjustable table can be incorporated into the structure.

fr Nuvola est un fauteuil monobloc qui transmet une sensation de chaleur et de bien-être à l'environnement dans lequel il est intégré. Les différents modèles sont disponibles en version à pieds chromés ou bois, ou à pied pivotant. Une petite table orientable peut être intégrée à la structure.



finishes
Rubelli Wabi 0023



finishes

1. RC 6501
-



finishes

2. LN 2535 / 3. Kvadrat Rime 0911

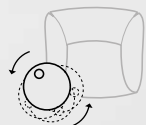

it_Tavolino scrittoio girevole.
en_Pivoting coffee table.
fr_Tablette pivotante.



finishes

1. ML 0002



finishes

 2-3. ML 0022

it_Base piatta con colonna
girevole autoallineante.
en_Swivel column base with
automatic return system.
fr_Socle pivotant à retour
automatique.

128

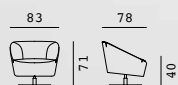

finishes

1. Kvadrat Remix 2 0852 /
 2. Kvadrat Remix 2 0973
-

it_Opzionale: cucitura a pettine.
en_Optional: blanket stitch detailing.
fr_En option : couture point de feston.

129

finishes

3. Rubelli Wabi 0023

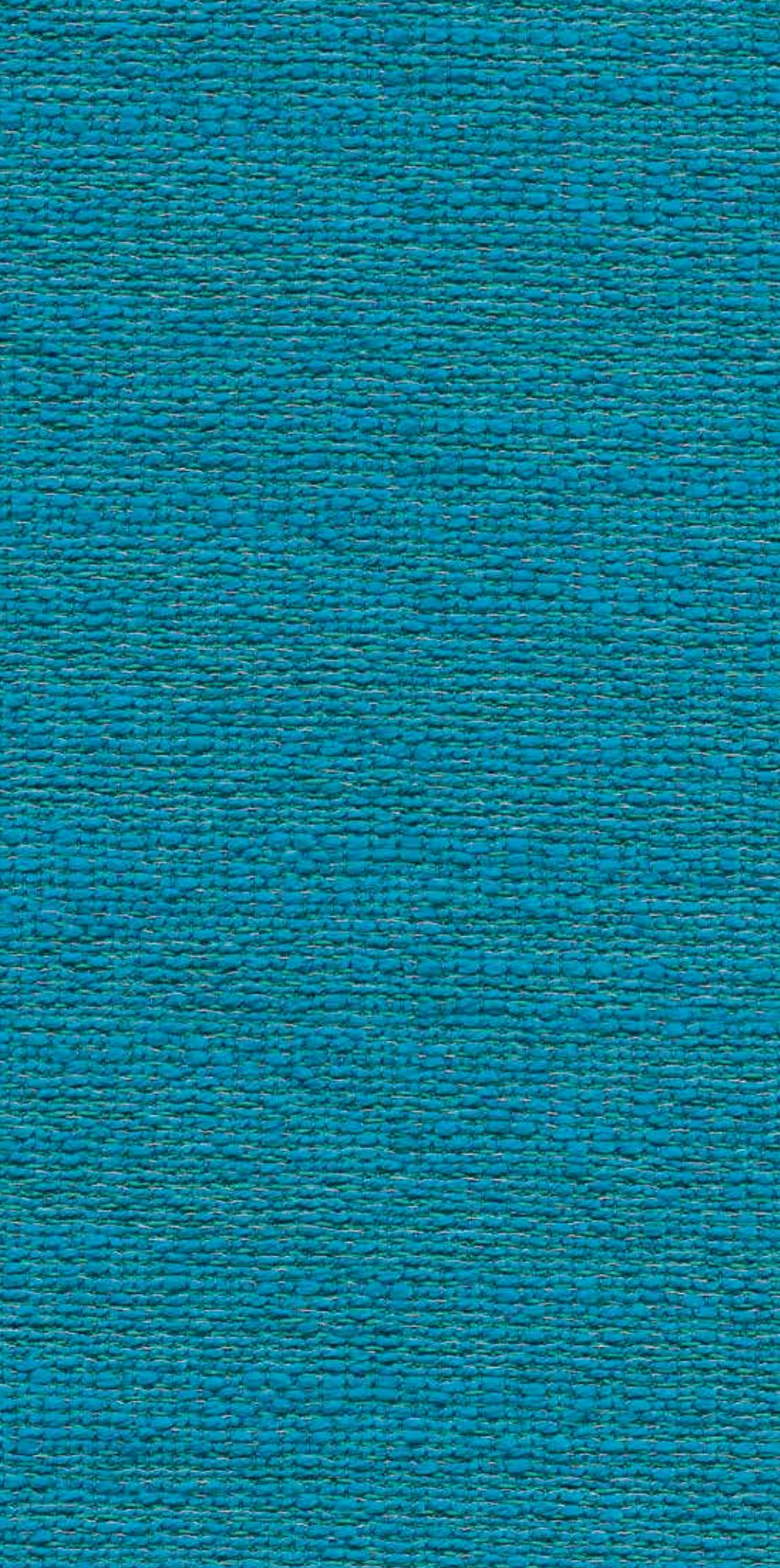

**Milani
in collaborazione
con Rubelli.**

**Milani in collaboration
with Rubelli.**

**Milani en collaboration
avec Rubelli.**

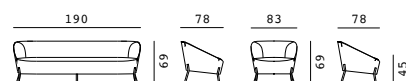

**finishes**

1. RC 6501 / 2. ML 0022

people

132

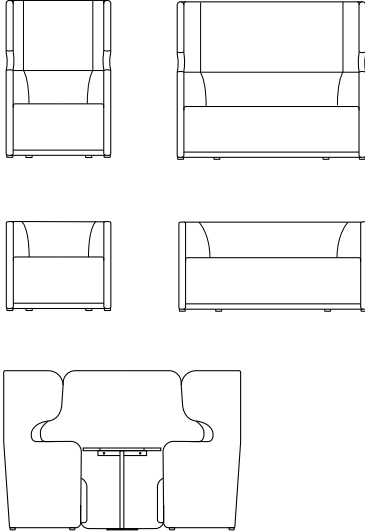

designer

Alessandro Crosera

it Forme fluide e versatili caratterizzano i divani e le poltrone People, proposti con schienale basso o alto. Nella versione privacy con scrivania creano aree di attesa e postazioni di incontro, garantendo l'isolamento necessario in ambienti open space. Possono essere dotati di presa elettrica e USB, e/o tasca laterale portariviste.

en Fluid, versatile shapes distinguish People sofas and armchairs, available with low or high backrest. The pod version with its individual desk is perfect for waiting areas and meeting areas, guaranteeing the privacy required for open-plan environments. These sofas can be equipped with power and USB sockets, and/or a side magazine pocket.

fr Les canapés et fauteuils People, à dossier haut ou bas, sont caractérisés par des formes fluides et polyvalentes. Dans la version à cellule, ils sont parfaits pour les zones d'attente et de rencontre, donnant l'intimité nécessaire dans un open space. Ils peuvent être équipés de prise électrique et USB et/ou de poches de rangement latérales.

**finishes**

1. Balani 0970 + Balani 0985

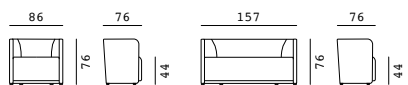

finishes

1-2. WM 0120 + WM 0143

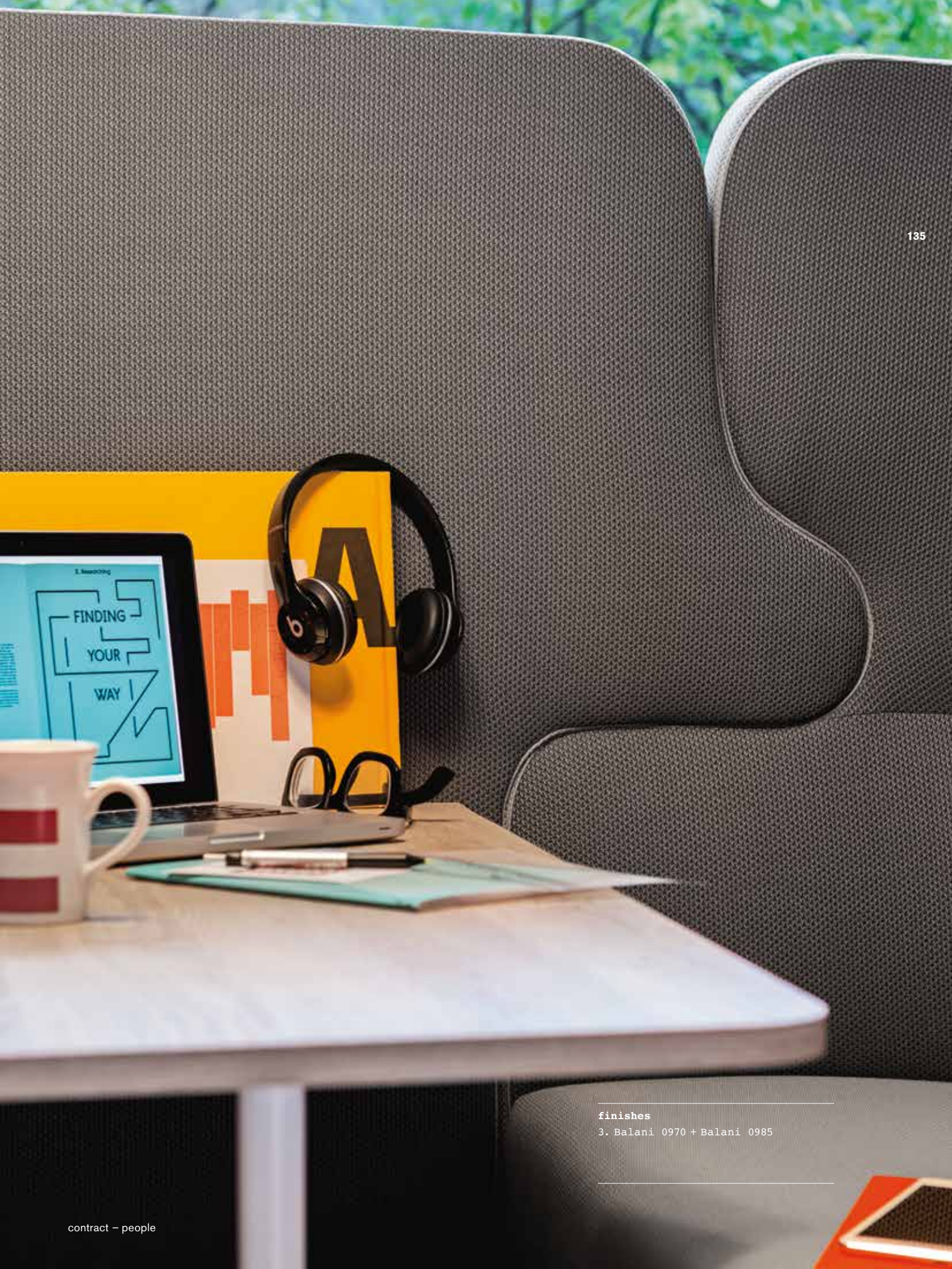

finishes
3. Balani 0970 + Balani 0985



finishes

1-4. Kvadrat Rime 0721 + Remix 2 762 /
5. Kvadrat Rime 0731 + Remix 2 0632

it_Presa elettrica e USB.
en_Electrical and USB socket.
fr_Prise électrique et USB.

137



**Milani
in collaborazione
con Kvadrat.**

**Milani in collaboration
with Kvadrat.**

**Milani en collaboration
avec Kvadrat.**



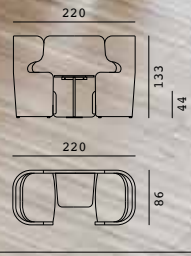

finishes
Rime 0721 +
Remix 2 762



finishes

- 1. Kvadrat Rime 0721 + Remix 2 0762 /
 - 2. Kvadrat Rime 0781
-



it_Tasca portariviste.
en_Magazine side pocket.
fr_Poche porte-magazines.

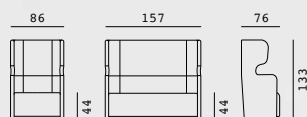

finishes

WM 0101 + WM 0142



shock

144

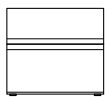

A.

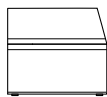

B.

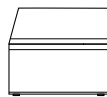

C.

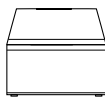

D.



E.

designer

Alessandro Crosera

it_Shock è un sistema modulare di sedute che può essere configurato come composizione articolata costituita da più elementi o come divano singolo, dove i braccioli ne definiscono i confini.

en_Shock is a modular seating system that can be configured as a combination of elements or as a single sofa, whose limits are defined by where the arms are placed.

fr_Shock est un système d'assises modulable : il peut être composé de plusieurs éléments, ou d'un seul canapé, les limites étant posées par les accoudoirs.



it_Moduli
en_Modules
fr_Modules

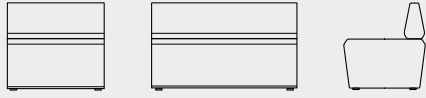

A.1 80 cm

A.2 120 cm

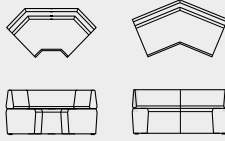

A.3-4

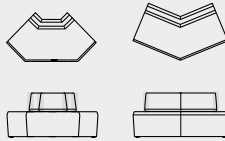

A.5-6



A.7

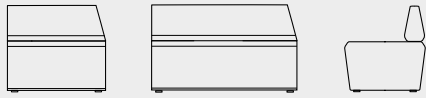

B.1 80 cm

B.2 120 cm

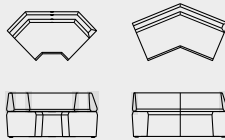

B.3-4

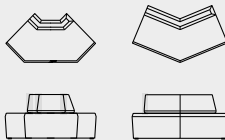

B.5-6

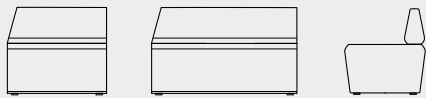

C.1 80 cm

C.2 120 cm

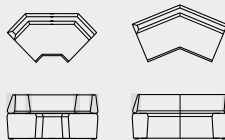

C.3-4

it_Moduli
en_Modules
fr_Modules

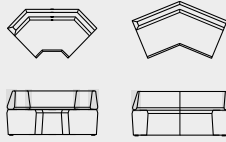

C.5-6

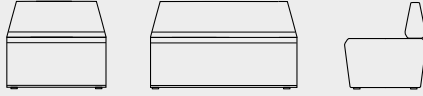

D.1 80 cm D.2 120 cm

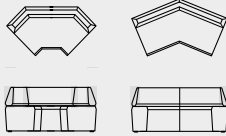

D.3-4

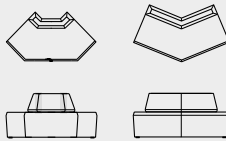

D.5-6

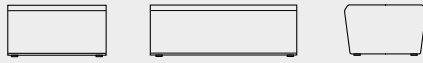

E.1 80 cm E.2 120 cm

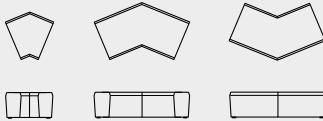

E.3-5



E.6

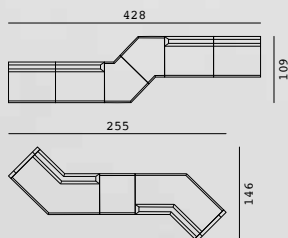

finishes

1. ML 0022 / 2. ML 0036 + ML 0034

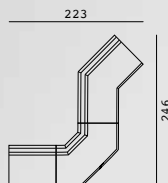

finishes

3. ZS 02DO + ZS 08IA

cocktail

148

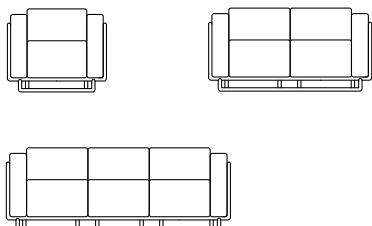

designer

Alessandro Crosera

it Ampi volumi geometrici definiscono la poltrona e il divano, a due e tre posti. I cuscini amovibili sono trattenuti da una struttura tubolare metallica, proposta anche in finitura cromata, verniciata bianca o antracite.

en Large geometric shapes define this armchair and two- and three-seat sofa. The detachable cushions are held in place by a tubular metal frame, also available in chrome, white-painted or anthracite finishes.

fr Les fauteuils et le canapé à deux ou trois places affichent des volumes géométriques. Les coussins amovibles sont maintenus par une structure tubulaire métallique, également disponible en finition chromée, vernie blanche ou anthracite.



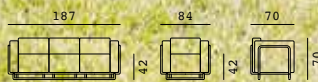

finishes

1. Balani 0985 / 2. Balani 0223

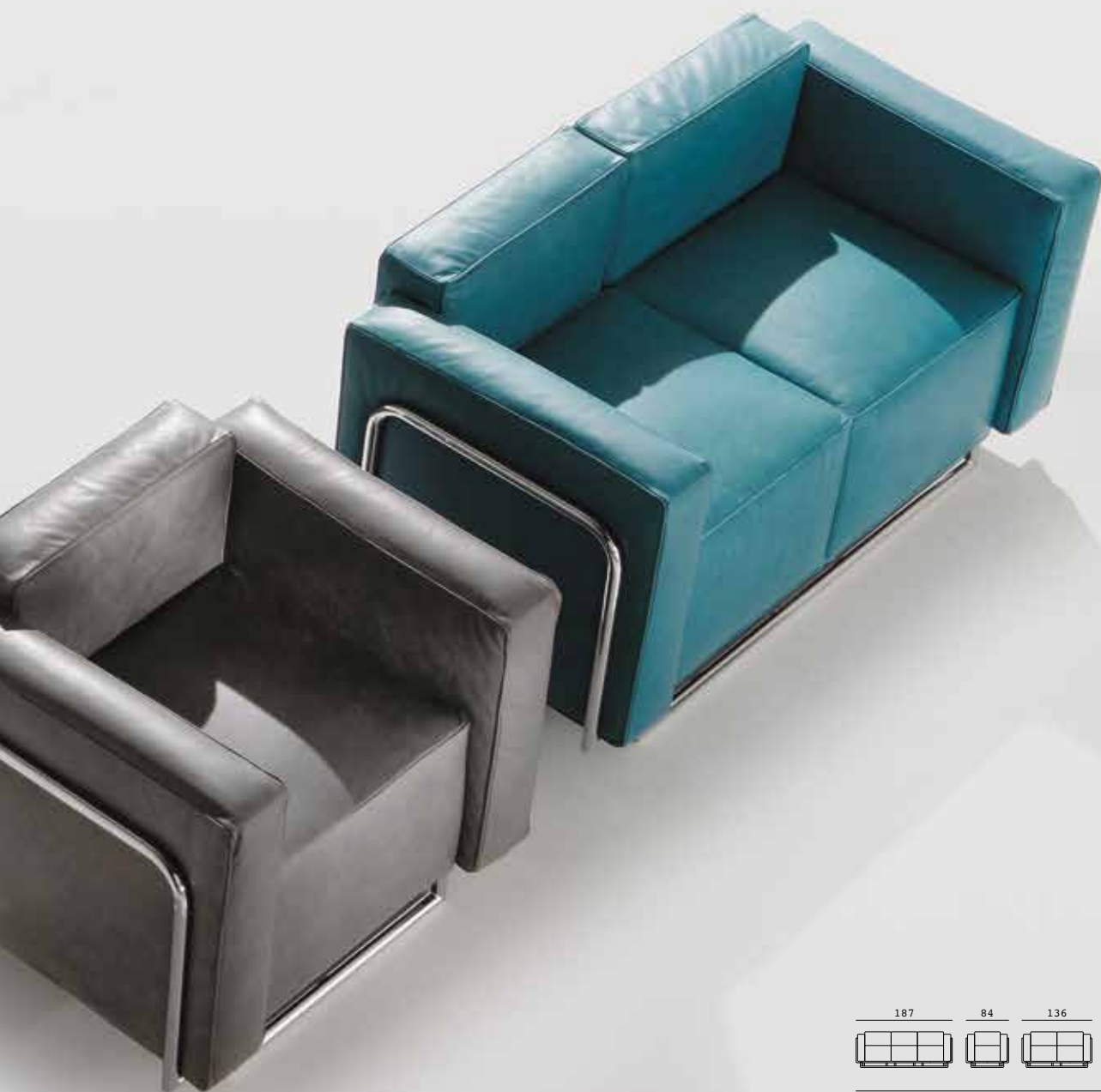

**finishes**

1. SK 0691 / 2. SK 0855 / 3. SK 0778

nesis

152

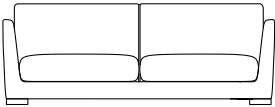
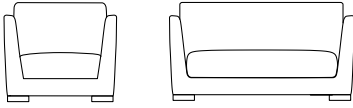

designer

Alessandro Crosera

it Poltrona e divano classici dalle forme piene, a due e tre posti, disegnati sia per l'ambito contract che per quello privato. I piedini possono essere tondi o quadrati in acciaio cromato. Il sedile e lo schienale sono rimovibili.

en A classic fuller-form armchair and sofa, available in two- or three-seat versions, perfect for contract settings or private homes. The chromed steel feet can be round or square. The seat and the backrest are removable.

fr Fauteuil et canapé classiques aux formes pleines, à deux ou trois places, conçus aussi bien pour l'espace de détente au travail que pour le domicile. Pieds arrondis ou carrés en acier chromé. L'assise et le dossier sont amovibles.



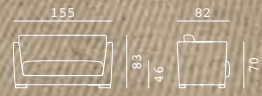

finishes
ML 0024

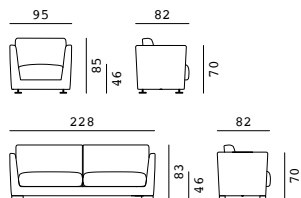

finishes

1. WM 0130 / 2. WM 0101 / 3. ML 0024



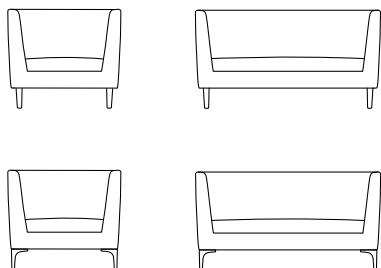

designer

Alessandro Crosera

it Poltrona e divano a due posti, elegantemente rifiniti, pensati per le sale d'attesa e gli hotel. L'ampia gamma di tessuti, pelli e colori e la possibilità di scegliere tra piedini in metallo cromato o in legno verniciato, consentono infinite combinazioni e personalizzazioni. Il sedile è rimovibile.

en A refined, elegant armchair and two-seat sofa, designed for waiting rooms and hotels. The wide range of fabrics, leathers and colours and the possibility to choose between chromed metal or varnished wood feet allow infinite combinations and a high degree of personalisation. The seat is removable.

fr Fauteuil et canapé deux places, à finition élégante, pensé pour les salles d'attente et les hôtels. La vaste gamme de tissus, de cuirs et de coloris disponibles et la possibilité de choisir entre des pieds en métal chromé ou en bois verni permettent une personnalisation et des combinaisons infinies. L'assise est amovible.



finishes
RC 3508



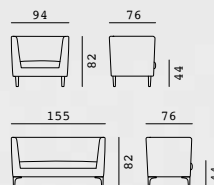

finishes

1. AB 0003 / 2. WM 0133 / 3. RC 2505

handle office

160



A.



B.



C.

designer

Alessandro Crosera

it Divano modulare dalle dimensioni compatte e dal distintivo tratto asimmetrico tra sedile e schienale che rende le composizioni varie e creative. L'interno è realizzato in legno con cinghie elastiche e piedini antiscivolo.

en A modular sofa with compact dimensions and a distinctive disrupted line between the seats and the backrests mean that this piece can be put together in different creative compositions. The frame is made of wood with elastic bands and anti-slip feet.

fr Ce canapé modulable aux dimensions réduites se distingue par l'asymétrie entre l'assise et le dossier, qui rend possibles des compositions variées et créatives. L'intérieur est composé de bois et de sangles élastiques, et les pieds disposent d'un système antiglisse.



contract – handle office

it_Moduli
en_Modules
fr_Modules

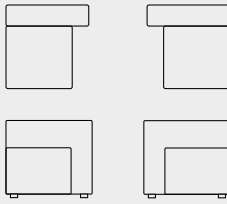

A.1-2

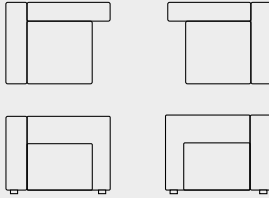

A.3-4

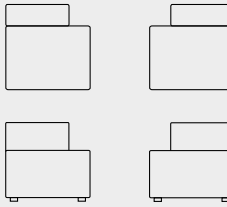

B.1-2

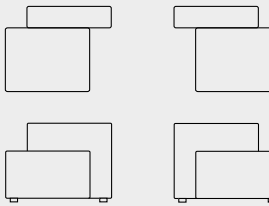

B.3-4

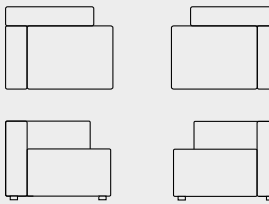

B.5-6

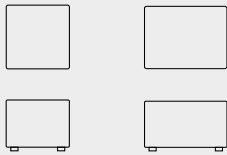

C.1-2

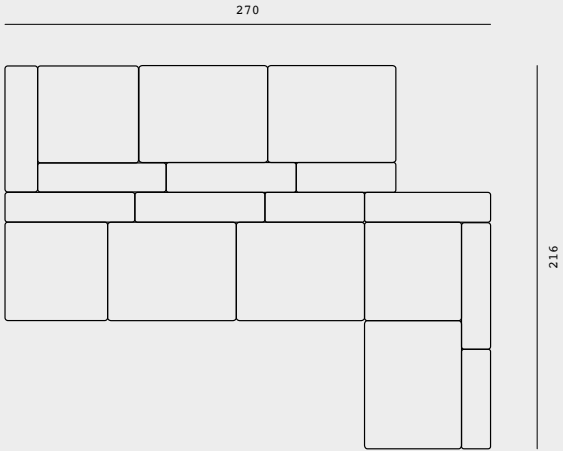
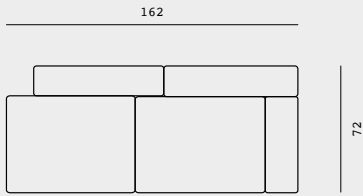

finishes

1. Rime 0641 / 2-3. WM 102 + Rime 0641
-

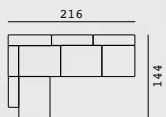

finishes
1. TA 2450



finishes

2. WM 0102 + Rime 0641

block

164

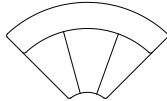
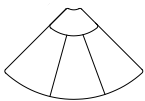
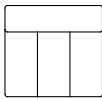

designer

Alessandro Crosera

it Divano componibile caratterizzato da quattro modularità differenti con struttura tubolare cromata a vista. La lunghezza variabile degli elementi consente molteplici configurazioni per adattarsi ad ogni spazio. Lo schienale funge anche da bracciolo.

en A modular sofa featuring four different modules with an exposed chrome tubular frame. The varying lengths of the components make multiple configurations possible, making this sofa suitable for any space. The backrest also functions as an armrest.

fr Canapé modulable caractérisé par quatre modules différents, avec structure tubulaire chromée apparente. La longueur variée des éléments permet de nombreuses configurations, pour une intégration dans chaque espace. Le dossier peut également servir d'accoudoir.

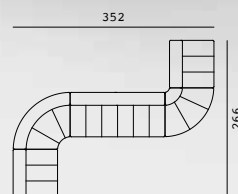
**finishes**

1, 4. RC 6501 / 2, 5. RC 8501 /
3. RC 8030



finishes
MA 0304



daisy

168

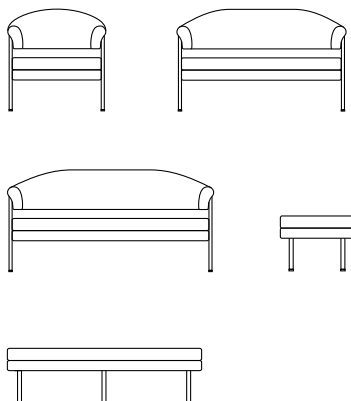

designer
R&D Milani

it Seduta accogliente e invitante, con sedile imbottito e rivestito in finitura capitonné. Disponibile nella versione poltrona singola, divano a due posti o maggiorato, panchina. Le gambe sono in metallo cromato.

en A welcoming, inviting chair with a padded seat covered in buttoned fabric. Available as a single armchair, a sofa with two or more seats and as a bench. The legs are in chromed metal.

fr Un siège accueillant à assise rembourrée et revêtement capitonné. Disponible dans la version fauteuil simple, canapé deux places ou plus, et banquette. Les pieds sont en métal chromé.



**finishes**

1, 3. Rubelli Cortez 0013 / 2. LN 6644

**Quando progettiamo
pensiamo ad ogni
singolo particolare,
affinché ogni elemento
costitutivo sia in
sintonia con il tutto.**

**When we design an item,
we think of every single detail,
to ensure each individual element
is in harmony with the whole.**

**Pendant la conception, nous
pensons au moindre détail
pour que chaque élément
soit en harmonie avec le tout.**



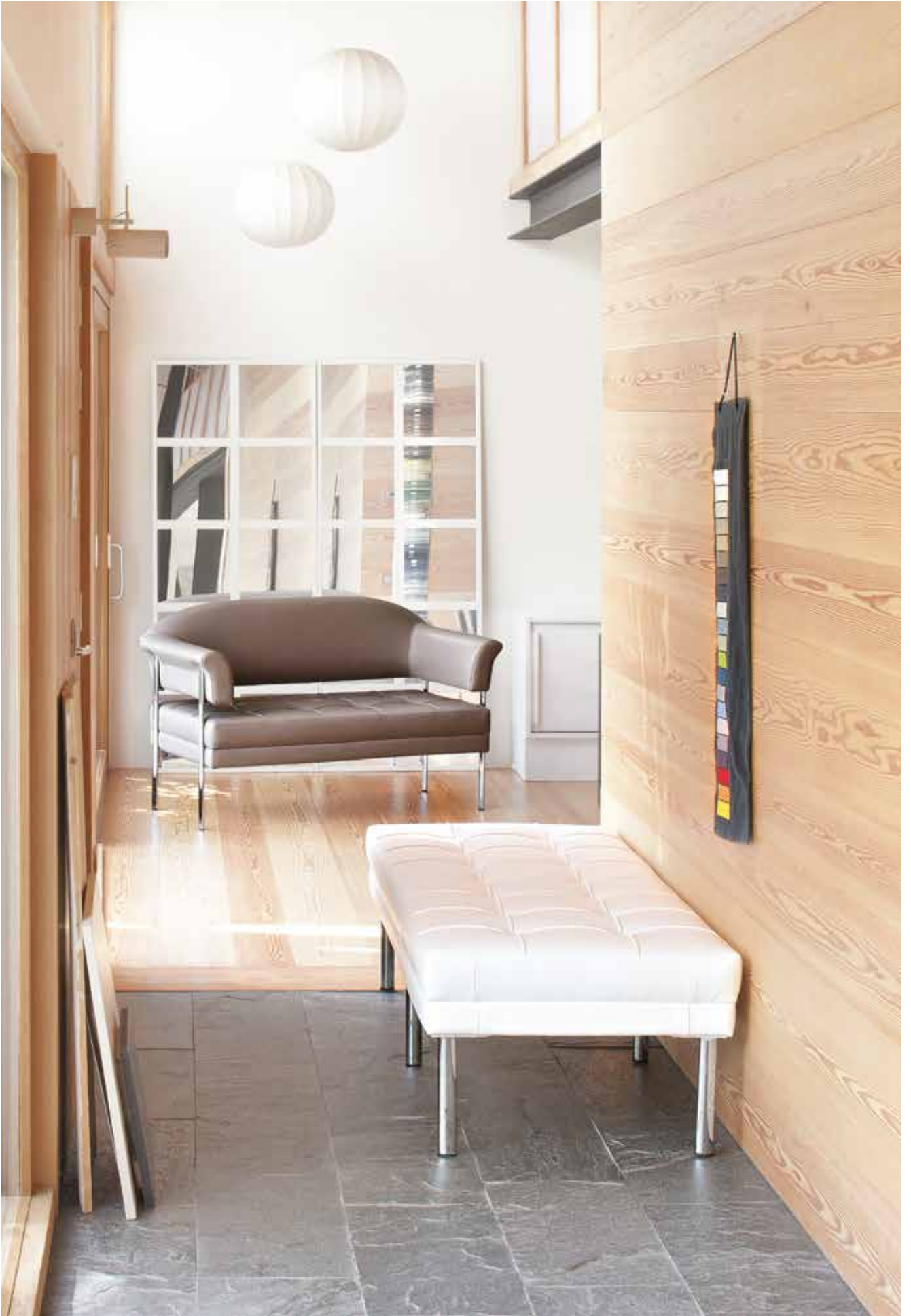

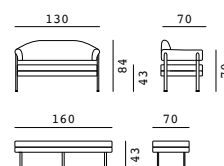

finishes

1. LN 3396 / 2. LX 0018 / 3. LN 3396

only

172

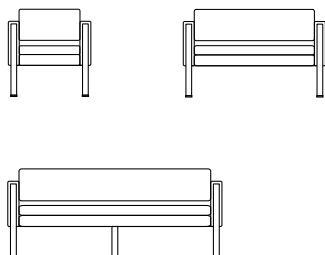

designer
R&D Milani

it Famiglia di sedute dal design rigoroso. Struttura in legno, inserti bracciolo e gambe in metallo cromato o antracite. Disponibile in versione poltrona, o divano a due o tre posti.

en A family of seats with a striking design. Built of wood with arm inserts and legs in a chrome or anthracite metal finish. Available as an armchair or as a two- or three-seat sofa.

fr Ces sièges affichent un design rigoureux. Ils possèdent une structure en bois, et les accoudoirs et les pieds sont en métal chromé ou anthracite. Disponibles en version fauteuil ou canapé deux ou trois places.

**finishes**

1. ZS 06KU / 2. MA 0403





finishes

TA 1950

genesis

176



designer
R&D Milani

it Un tratto libero e armonico disegna la silhouette della poltrona lounge. La scocca è in schiumato a freddo, la base è in metallo cromato o bianca. Le fasce laterali sono in tinta con il rivestimento o in finta pelle bianca.

en Flowing, harmonious lines create the silhouette of this lounge chair. The body is made of injected foam, while the base comes in white or chromed metal. The sides can be the same colour as the covering or in white faux leather.

fr Une ligne svelte et harmonieuse dessine la silhouette de ce fauteuil lounge. Sa structure est en mousse injectée, et son piétement est en métal chromé ou blanc. Bandes latérales disponibles dans le même ton que le revêtement ou en similicuir blanc.



finishes

1. LN 3348 + LN 339 / 2. LN 6644 /
3. LN 2527 / 4. LN 2511





finishes

1. WM 0101 / 2. WM 0112 / 3-4. LN 2535

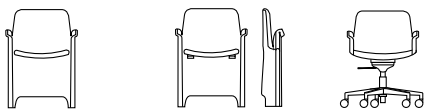

designer

Orlandini Design

it Un segno dinamico e un profilo sottile caratterizzano la poltroncina in schiumato. Lo schienale flessibile dona maggiore comfort alla seduta. È possibile scegliere tra numerosi modelli di basi, nella versione con sedile ribaltabile ha un ingombro contenuto.

en A striking design and a subtle profile define this chair made of injected foam. The flexible back gives the chair greater comfort. Choose from various types of base. The folding version is a great space-saving option.

fr Esprit dynamique et profil fin distinguent ce fauteuil en mousse injectée. Son dossier flexible offre un confort accru. De nombreux modèles de piètements sont disponibles. La version à assise pliante présente l'avantage d'un encombrement petit.



finishes

1. MA 0901 / 2. MA 0706 / 3. MA 0304 /
4. MA 0804 / 5. MA 0803





finishes

1. MA 0022 / 2. ZS 06KN / 3. AB 0002 /
4. TF 0010 / 5. ZS 02DO
-





finishes

1. MA 0804 / 2. ZS 03CV / 3. LN 6400 /
4. CX 0210
-



finishes

1. WM 0143 / 2, 4. WM 0120 / 3. WM 0133

it_Schienale flessibile.
en_Flexible backrest.
fr_Dossier flexible.

187







finishes
ML 0022

liliè

190



designer
R&D Milani

it_Confortevole poltroncina inseribile in diversi ambienti: dall'ufficio direzionale all'area attesa. Lo schienale dall'ampio raggio e dalle forme gentili offre un piacevole momento di riposo. È proposto anche nella versione autoallineante.

en_A comfortable armchair suitable for all types of setting: from the boardroom to the waiting area. The pleasant shape and generous curve of the seatback offer a pleasant moment of relaxation. Also available in swivel version with automatic return to centre.

fr_Ce fauteuil confortable peut s'intégrer à différents espaces, allant du bureau de direction à la salle d'attente. Son dossier enveloppant à la forme délicate offre un moment de repos très agréable. Disponible dans la version à retour automatique.





finishes
Rubelli Cortez 7976





it_Base piatta con colonna
girevole autoallineante.

en_Flat base with
auto-return system.

fr_Piétement plat à
retour automatique.

finishes

1. Rubelli Cortez 0020 / 2. CX 0031 /
3. ZS 08IA
-

tulip

194



designer
R&D Milani

it Tulip ricorda la corolla di un tulipano. La scocca in legno imbottito è completamente rivestita. Il bordino, disponibile in tinta o a contrasto, dona ulteriore pregio al modello. La base girevole è in alluminio a quattro razze o piatta tonda e cromata.

en Inspired by the shape of a tulip, this design has a body made of wood, padded and fully upholstered. The piping, available in matching or contrasting colours, lends the model additional prestige. The swivel base comes in a four-star aluminium version or as a round chrome plate.

fr Tulip rappelle la forme de la tulipe. La structure en bois rembourré est entièrement revêtue. Ton sur ton ou contrastant, le passepoil confère davantage de charme au modèle. Le piètement pivotant est en aluminium à quatre branches ou à socle rond chromé.



finishes

1. NB 0013 / 2. WM 0120

ellipse

196

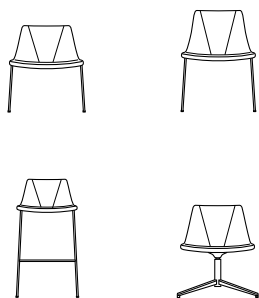

designer
R&D Milani

it_Famiglia di sedute con scocca in legno destinate agli ambienti d'attesa e conferenza. Vengono proposte completamente rivestite e con base slitta in tondino cromato. La versione lounge può avere anche la base in alluminio a quattro razze e sistema oscillante.

en_A family of chairs made of wood designed for waiting areas and conferences. Available fully upholstered with chrome tubular sled base. The lounge version also comes with a four-star aluminium base and tilt system.

fr_Ces sièges à structure en bois sont pensés pour les salles d'attente et les conférences. Entièrement revêtus, ils sont dotés d'un piétement traineau chromé. La version lounge est disponible en piétement avec système basculant en aluminium à quatre branches.





finishes

1. MA 0803 / 2. RC 8030 / 3. RC 8051



finishes

1. LN 3396 / 2. LN 5432 / 3. RC 8030

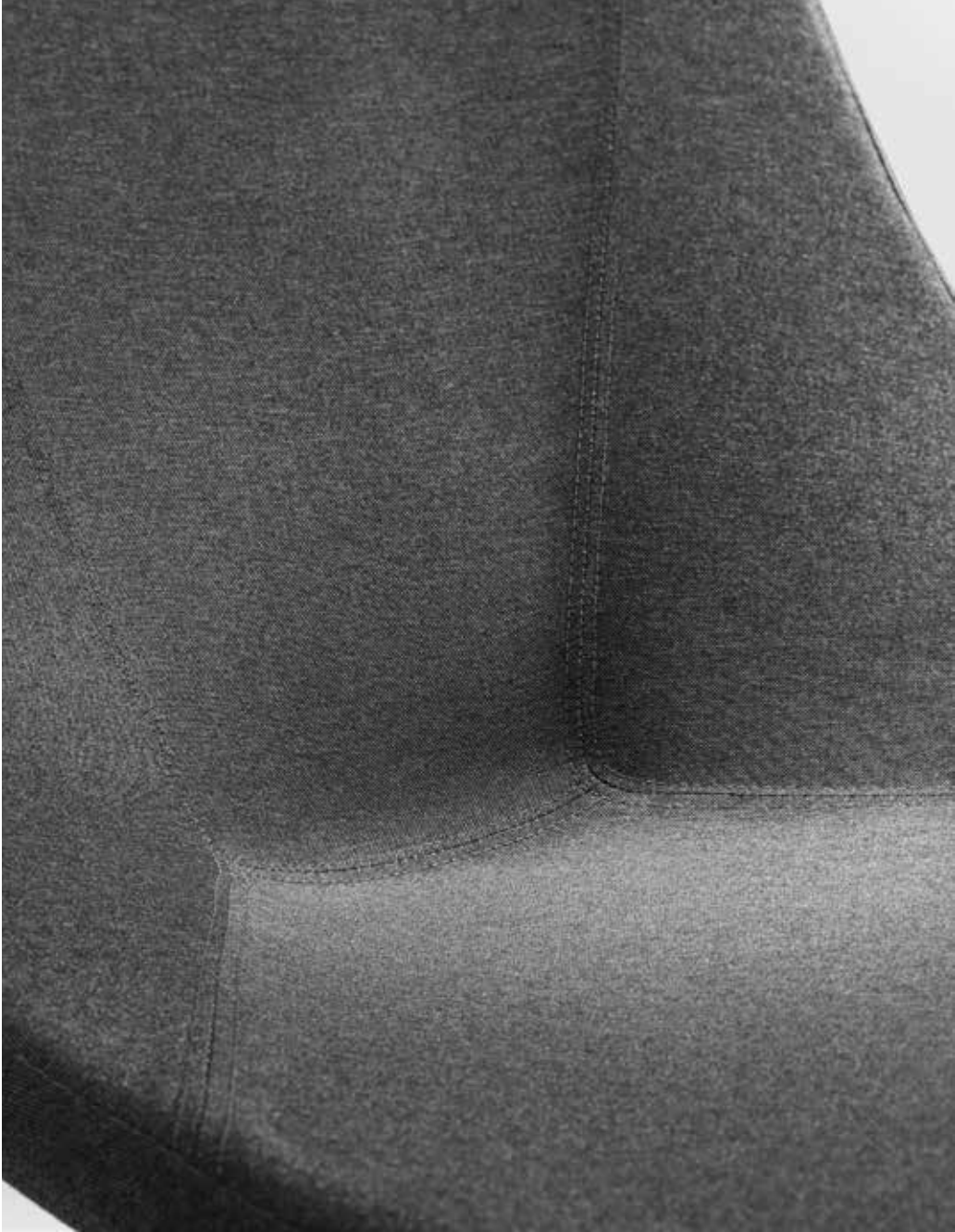

patch work

200



designer

Alessandro Crosera

it Poltroncina dedicata agli ambienti collettivi e riunione, con o senza braccioli rivestiti. L'imbottitura è in schiumato a freddo ad alta densità con meccanismo oscillante. La base in alluminio può essere con ruote o piramidale verniciata bianca con piedini.

en An armchair designed for communal areas and meetings, with or without upholstered armrests. The padding is made of high density cold foam with a tilt mechanism. The aluminium base comes with wheels or with four white-painted pyramid legs.

fr Fauteuil destiné aux espaces collectifs et de réunion, avec ou sans accoudoirs revêtus. Rembourrage en mousse froide haute densité et mécanisme pivotant. Le piétement en aluminium est disponible en version à roulettes ou pyramide blanche vernie à pieds.



finishes
LN 5432 + TA 0250

**Siamo convinti
che nel nostro lavoro
sia importante realizzare
sedute di qualità,
contraddistinte da
ergonomia e comfort.**

**We are convinced that in our line
of work, it's important to build
quality chairs that guarantee
excellent comfort and efficiency.**

**Nous sommes convaincus que,
dans notre travail, il est important
de créer des sièges de qualité,
caractérisés par leur ergonomie
et leur confort.**





finishes

1. ML 0014 / 2-3. MA 0304



adalia

204



designer
R&D Milani

it Una linea fluida definisce il volume di questa poltroncina. I raffinati accostamenti cromatici ne consentono l'inserimento in diversi contesti. La seduta e lo schienale sono realizzati in schiumato a freddo ad alta densità. È proposta con base cromata o con base in legno a quattro gambe.

en Flowing lines define the shape of this chair. The sophisticated chrome detailing makes this design suitable for all types of setting. The seat and back are made of high density injected foam. Choose from a chrome base or four wooden legs.

fr Ce fauteuil se caractérise par un volume aux lignes fluides. Les associations de couleurs raffinées permettent une intégration dans différents contextes. Le siège et l'assise sont réalisés en mousse injectée haute densité. Piétement chromé ou en bois à quatre pieds.





finishes
Kvadrat Rime 0911





finishes

1. Kvadrat Remix 2 0722 / 2. AB 0003 /
 3. Kvadrat Remix 2 0753
-

terre

208



designer

Alessandro Crosera

it Terre è un pouf bombato, leggero e dinamico. Realizzato in due dimensioni, il bordino può essere in contrasto o in tinta con il rivestimento scelto.

en Terre is a rounded pouf with a light, dynamic feel. Created in two parts, the piping can be the same as the chosen covering or in a contrasting colour.

fr Terre est un pouf rebondi, léger et dynamique. Réalisé en deux dimensions différentes, la couleur du passepoil peut être contrastante ou du même ton que le revêtement choisi.



finishes
1. WM 0112 / 2. WM 0120 / 3. WM 0130

**Per noi know-how
significa conoscenza:
è il metodo di lavoro,
è la competenza
che contraddistingue
il nostro operare.**

**For us, expertise means
knowledge: it's the skill
that defines how we work.**

**Pour nous, le savoir-faire est
synonyme de connaissance :
c'est notre méthode de travail,
la compétence qui nous distingue.**



Mack

MADE IN U.S.A.
KNEE-DRIVEN

1770

GREASE





finishes

1-2. ML 0035 + ML 0024 /

3. ML 0024 + ML 0013 / 4. ML 0013

fungus

212



designer

C/B Design

it_Pensata per i momenti conviviali e di relax, Fungus è perfetta come seduta informale per gli spazi contract. Le sue dimensioni contenute lo rendono un accessorio pratico e divertente. La struttura in plastica è completata dal cuscino ruotante imbottito.

en_Created for social occasions and leisure, Fungus is the perfect informal seat for contract spaces. Its compact dimensions make it practical and fun. The plastic body is completed by a round upholstered cushion.

fr_Pensé pour les moments conviviaux et de détente, le fauteuil Fungus est parfait dans des contextes informels ou dans les espaces de repos. Ses dimensions réduites en font un accessoire pratique et ludique. Sa structure en plastique est complétée d'un coussin rembourré pivotant.



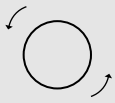

it_Cuscino ruotante.
en_Rotating cushion.
fr_Coussin pivotant.



it_Seduta dondolante.
en_Rocking seat.
fr_Siège basculant.



finishes

1. RC 8501 / 2. RC 8030 / 3. RC 6508 / 4. ZS 02F1 /
5. RC 4504 / 6. TA 1950 / 7. RC 7504



ESSE SOLUTION_{SAGL}

FORNITURE AZIENDALI

Via Rompada, 37 - CASLANO

+41 076 758 5368 +41 079 709 8354

www.essesolution.ch info@essesolution.ch

wait

wait

216



colette
p. 218



voilà
p. 222



clark
p. 228



lois
p. 236



wendy
p. 242



dolly
p. 248



role
p. 254



blend
p. 258



venice
p. 262



time
p. 266



fuego
p. 268

conferenza – collettività – attesa

Serie di sedute che si caratterizza per versatilità di utilizzo, dedicata agli spazi per la ristorazione – bar, caffetterie e sale mensa – aree meeting, d'attesa e conferenza.

Flessibili e personalizzabili, i modelli combinano tecnica, materiali – plastica e metallo, con rivestimento in cuoio o in tessuto – e colori, nel segno del comfort.

conference – visitor seating

A series of chairs distinguished by their versatility, designed for catering spaces (bars, cafeterias and dining halls), meeting areas, waiting areas and conference venues.

Flexible and customisable, these models combine engineering, materials – plastic and metal, with leather or fabric upholstery – and colours to give the ultimate in comfort.

chaises conférence – visiteur

Série de sièges caractérisés par une grande polyvalence, pensés pour les espaces de restauration ou les bars, les cafétérias et les cantines. Flexibles et personnalisables, les modèles associent technique, matériaux tels que le plastique ou le métal revêtus de cuir ou de tissu, et couleurs, toujours sous le signe du confort.

designers

Alessandro Crosera
Orlandini Design
R&D Milani

colette

218

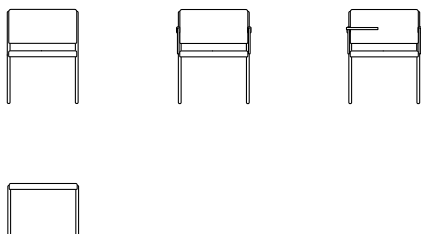

designer

Alessandro Crosera

it Il tubo in metallo cromato diventa la struttura di questa poltroncina, con sedile e schienale imbottito, dedicata alla collettività. Disponibile anche con braccioli e tavolino scrittoio per le conferenze.

en Chromed metal tube provides the frame of this armchair, with padded seat and back, designed for public areas. Also available with arms and writing tablet for conferences.

fr Le tube en métal chromé constitue la structure de ce fauteuil, agrémenté d'une assise et d'un dossier rembourrés, parfaites pour les collectivités. Accoudoirs et tablettes disponibles pour les conférences.



finishes

1. WM 0101 / 2. WM 0143





finishes

1-2. NE 0120 / 3-5. RC 3503 /
6-8. Kvadrat Rime 0521

voilà

222

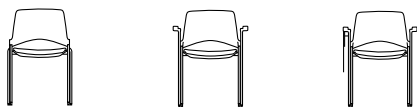

designer
R&D Milani

it Seduta duttile, con sedile ribaltabile, proposta con plastiche a vista o rivestita in tessuto, impilabile anche nella versione con tavolino scrittoio. Abbinata al tavolo ribaltabile crea una famiglia completa e funzionale.

en A flexible chair with a tip up seat, available in plastic or fabric finish and stackable even in the version with writing table. Combined with a foldable table, it forms a complete and fully functional family.

fr Siège maniable à assise pliante, proposé dans les versions plastique ou revêtue, empilable, également disponible dans la version à tablette. Associé à sa table pliante, il forme une famille complète et fonctionnelle.





finishes

1. RC 6508 / 2. RC 3508 /
3. RC 3503 / 4. RC 7503 / 5. RC 6501
-





finishes

1-3. PXV 033 / 4. PXV 034 / 5. PXV
034 + RC 4504 / 6. PXV 034 + RC 4504

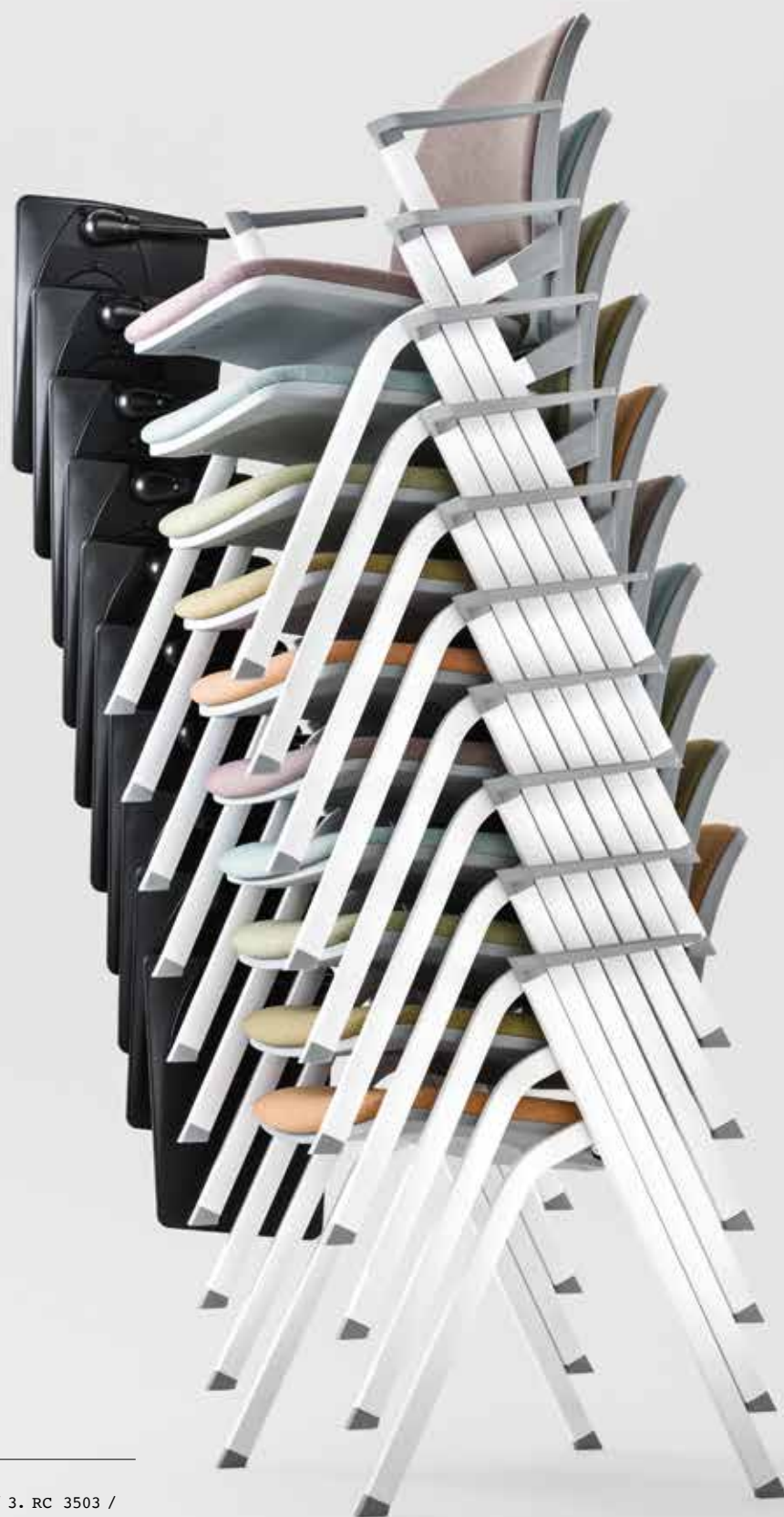

finishes

1. RC 6508 / 2. RC 3508 / 3. RC 3503 /
4. RC 7503 / 5. RC 6501
-



finishes

6. PXV 033 + NE 0643

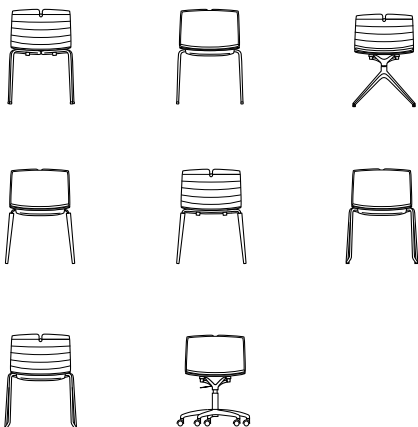

designer

Orlandini Design

it Seduta dal design senza tempo e dalle molteplici combinazioni cromatiche: è possibile scegliere il colore delle scocche in plastica, del bottone applicato sul retro e del sotto sedile. Proposta anche in versione imbottita e in quattro tipologie di basi: a slitta, a quattro gambe, in legno o girevole in alluminio.

en A chair with a timeless design and with endless possible colour combinations: choose the colour of the plastic body, the button feature on the back and the under seat. Also available upholstered and with four types of base: skid, four legged, wooden or aluminium swivel base.

fr Siège au design intemporel et aux multiples combinaisons de couleurs : il est possible de choisir la couleur des structures en plastique, du bouton à l'arrière et du dessous de l'assise. Proposé dans la version rembourrée et quatre piétements différents : traineau, quatre pieds, bois ou pivotant en aluminium.



finishes
PXC 052 + PXC 053 + RC 8502



finishes

1. PXC 070 + PXC 053 / 2. PXC 063 +
PXC 070 + Kvadrat Remix 2 0933



finishes

3. PXC 010 + PXC 053 / 4. PXC 070 +
PXC 070 + Kvadrat Remix 2 0973





finishes

1. PXC 010 + ML 0007 / 2. PXC 010 + ML 0035 /
3, 5. PXC 010 + ML 0022 / 4. PXC 010 + ML 0014



it Clark, caratteristiche tecniche.
en Clark, technical characteristics.
fr Clark, caractéristiques techniques.

235

it Otto colori di scocca,
tre colori di bottone,
tre colori di sotto sedile.
en Eight shell colors,
three button colors,
three underseat colors.
fr Huit couleurs de coque,
trois couleurs de bouton,
trois couleurs de sous assise.

it Quattro tipi di
basi in tre finiture.
en Four types of
bases in three finishes.
fr Quatre types de
piétements en trois finitions.



finishes

1. PXC 052 + PXC 053 + RC 8502 /
 2. PXC 010 + PXC 010 + ML 0007
-

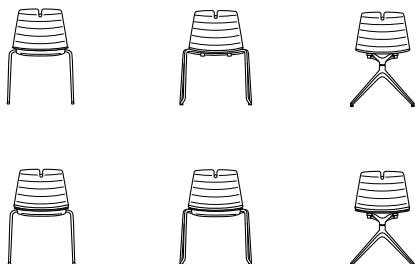

designer

Orlandini Design

it La seduta riprende l'estetica di Clark, anche nel dettaglio del bottone applicato sul retro, è proposta con proporzioni più contenute. È disponibile anche nella versione con sedile imbottito, base slitta, girevole in alluminio, a quattro gambe cromate o verniciate.

en This seat echoes the style of Clark, even down to the button detail featured on the back, but in more compact dimensions. Also available with an upholstered seat, skid base, aluminium swivel base, four-legged base (chrome or painted).

fr Siège rappelant l'esthétique de Clark, y compris dans la reprise du détail bouton à l'arrière, ses proportions sont plus réduites. Également disponible dans la version à assise rembourrée, et piètement traineau, pivotant en aluminium, quatre pieds chromés ou vernis.





finishes

1. PXC 063 + PXC 053 + WM 0101 /
 2. PXC 081 + PXC 010 + WM 0120
-



finishes

1. PXC 052 + PXC 053 /
 2. PXC 010 + PXC 050 + NE 0015
-



finishes

3-8. PXC 010 + PXC 070 / PXC 053 /
PXC 010 / 9. PXC 035 + PXC 010





finishes

1-2. PXC 063 + PXC 052 + WM 0101

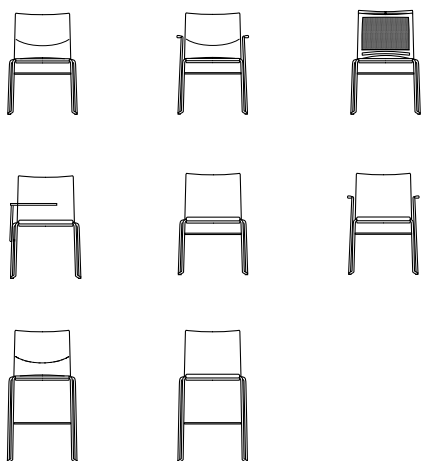

designer
R&D Milani

it Una seduta multifunzionale dal design essenziale, proposta con schienale in rete, in plastica, imbottita o in legno. Le combinazioni sono numerosissime grazie alla possibilità di rivestire anche solo il sedile e di scegliere tra basi in tondino cromato, con o senza braccioli, con tavolino scrittoio o nella versione sgabello.

en A multifunctional chair in a minimalist design, available with a mesh, plastic, upholstered or wooden back. The combinations are endless thanks to the possibility of covering just the seat and choosing between the various chrome skid bases with or without arms, with writing table or in barstool version.

fr Un siège multifonctions au design essentiel, avec dossier en résille, en plastique, rembourré ou en bois. De nombreuses combinaisons sont possibles. Vous pouvez choisir un revêtement pour l'assise seule, un piétement traineau chromé avec ou sans accoudoirs, avec tablette ou en version tabouret.



finishes
ML 0014





finishes

1. RC 3503 / 2, 4, 6. PXW 043 / 3, 5. PXW 044 /
7. PXW 046 / 8. PXW 41 + RT 0014





finishes

1. RC 3503 / 2. RC 3508 + RT 0015 /
 3. ZS 03CV + PXW 048 / 4. LG
-

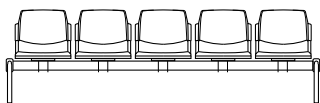
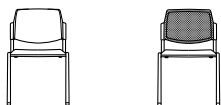

A.

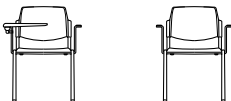

designer
R&D Milani

it Una collezione flessibile e adattabile alle diverse esigenze del mondo contract, dall'ampia gamma di varianti. Disponibile anche su panca nella versione fissa o ribaltabile, in rete, plastica o tessuto.

en A flexible collection that will adapt to the varying requirements of the contract world, thanks to a wide range of options. Also available as a bench in fixed or foldable versions, in mesh, plastic or fabric.

fr Une collection flexible, qui s'adapte aux différentes exigences des lignes détente, avec ses nombreuses variations possibles. Également disponible en version à banquette fixe ou pliante, en résille, plastique ou tissu.



finishes
PXD 090

it_Panche
en_Benches
fr_Poutres

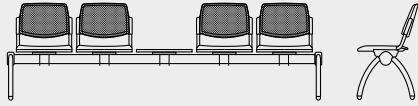

A.1

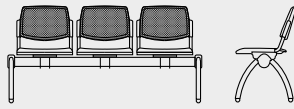

A.2

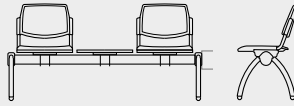

A.3

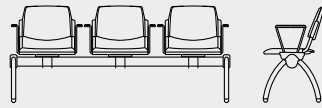

A.4

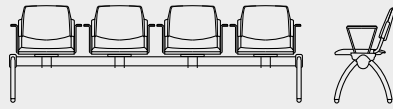

A.5

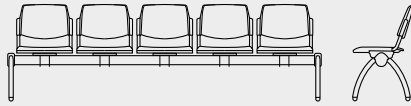

A.6

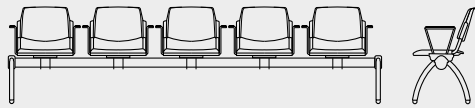

A.7

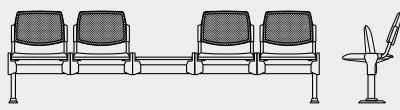

A.8

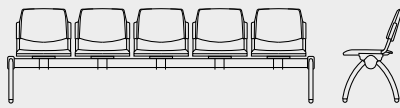

A.9

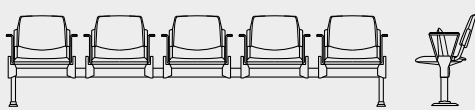

A.10

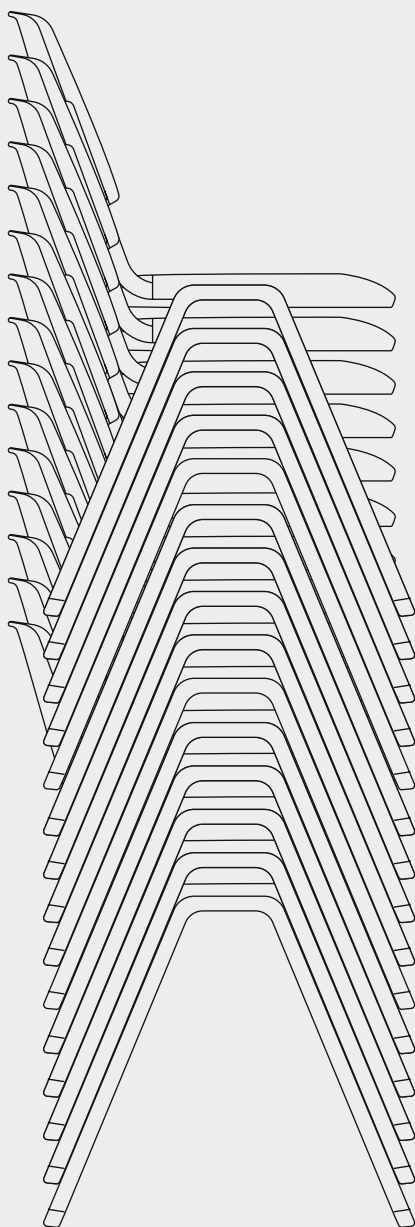

it Impilabile fino a quindici sedie, con o senza braccioli.

en Stacks up to fifteen chairs, with or without armrests.

fr Empilable jusqu'à quinze chaises, avec ou sans accoudoirs.





finishes

1. PXD 031 / 2. MA 0304 + PXD 071 /
 3. NE 0533 + RT 0015 / 4. TA 0650 + PXD 011
-



it_Panca con sedile ribaltabile
automatico.
en_Automatic tip up seat.
fr_Assise rabatable automatique.

253



finishes

1. NE 0643 + PXD 07 /
 2. NE 0333 + PXD 090
-

role

254



designer
R&D Milani

it_Il capiente portazaino, il sedile girevole e il tavolino scrittoio orientabile consentono di lavorare dovunque comodamente. Il design funzionale e le numerose cromie, rendono Role il prodotto ideale per gli ambienti accademici.

en_With its generous bag holder, swivel seat and writing table, this chair makes it possible to work in comfort anywhere. The functional design and numerous colour options make Role the ideal product for academic settings.

fr_Le grand porte-sac, l'assise pivotante et la tablette pivotante de Role permettent de travailler partout et confortablement. Son design fonctionnel et ses nombreux coloris disponibles en font un produit idéal pour les lieux académiques.





finishes

1. PXR 020 / 2. PXR 062 / 3. PXR 072



it_Tavoletta scrittoio
ambidestra e orientabile.
en_Ambidextrous and
directable writing tablet.
fr_Tablette écrioire
ambidextre et orientable.



finishes

1. RC 3503 + PXR 035 / 2-3. PXR 050



**Da oltre quarant'anni
creiamo sedute per
l'ufficio e il contract
con la stessa passione
e dedizione di sempre.**

**For over forty years now, we've
been applying the same enthusiasm
and dedication to creating seating
for the office and contract sector.**

**Nous réalisons des sièges de
bureau et pour les espaces de
détente depuis plus de quarante
ans, toujours avec la même
passion et le même dévouement.**



blend

258

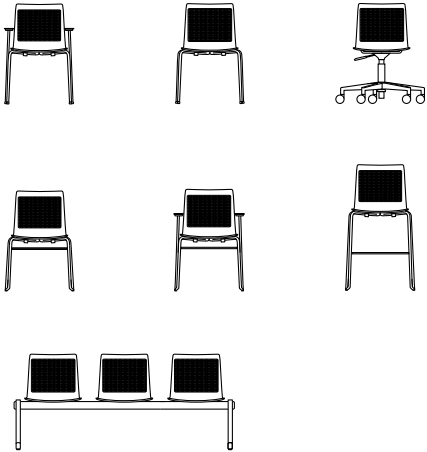

designer

R&D Milani

it Leggera e resistente, Blend è una seduta con scocca in plastica dalle numerose varianti colore, adattabile ai diversi ambienti: casa, ufficio e contract. Il particolare decoro a griglia dello schienale garantisce una perfetta ergonomia.

en Light and durable, Blend is a chair with a plastic base that comes in numerous colour options, adapting easily to different settings: home, office and contract. The distinctive grill design of the backrest guarantees perfect ergonomic performance.

fr Léger et solide, Blend est un siège à structure en plastique disponible dans de nombreux coloris. Il s'adapte aussi bien au domicile qu'au bureau, en passant par les espaces de détente. Son dossier à détail grille permet une ergonomie optimale.



finishes

1. PXB 060 / 2. ML 0024 + PXB 060





finishes

1. PXB 081 / 2. MA 0901 + PXB 082 /
 3. MA 0706 + PXB 090
-

venice

262

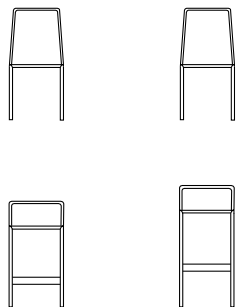

designer
R&D Milani

it_Dal design minimale e raffinato, Venice è una seduta multifunzionale, interamente rivestita in cuoio rigenerato o con gambe cromate.

È progettata con schienale alto o medio e nella versione sgabello.

en_With its elegant, minimalist design, Venice is a multifunctional seat, fully upholstered in recycled bonded leather or with chrome legs.

It comes in high-back or medium-back version and as a barstool.

fr_Venice, avec son design minimaliste et raffiné, est un siège multifonction, entièrement revêtu de cuir réconstitué ou à pieds chromés. Disponible avec dossier haut ou moyen et dans la version visiteur.

it_Impilabile (x5).
en_Stackable (x5).
fr_Empilable (x5).



finishes

1. CU 0279 / 2-4. CU 0278





finishes

1. CU 0275 / 2. CU 0282 /
3. CU 0273 / 4. CU 0277
-



designer
R&D Milani

it Poltroncina con braccioli, interamente rivestita in cuoio rigenerato, impreziosita dalle cuciture a vista.

en A high-sided chair, fully upholstered in recycled bonded leather, with feature stitchings.

fr Siège à accoudoirs, entièrement revêtu de cuir réconstitué, sur lequel les coutures apparentes apportent une touche élégante.

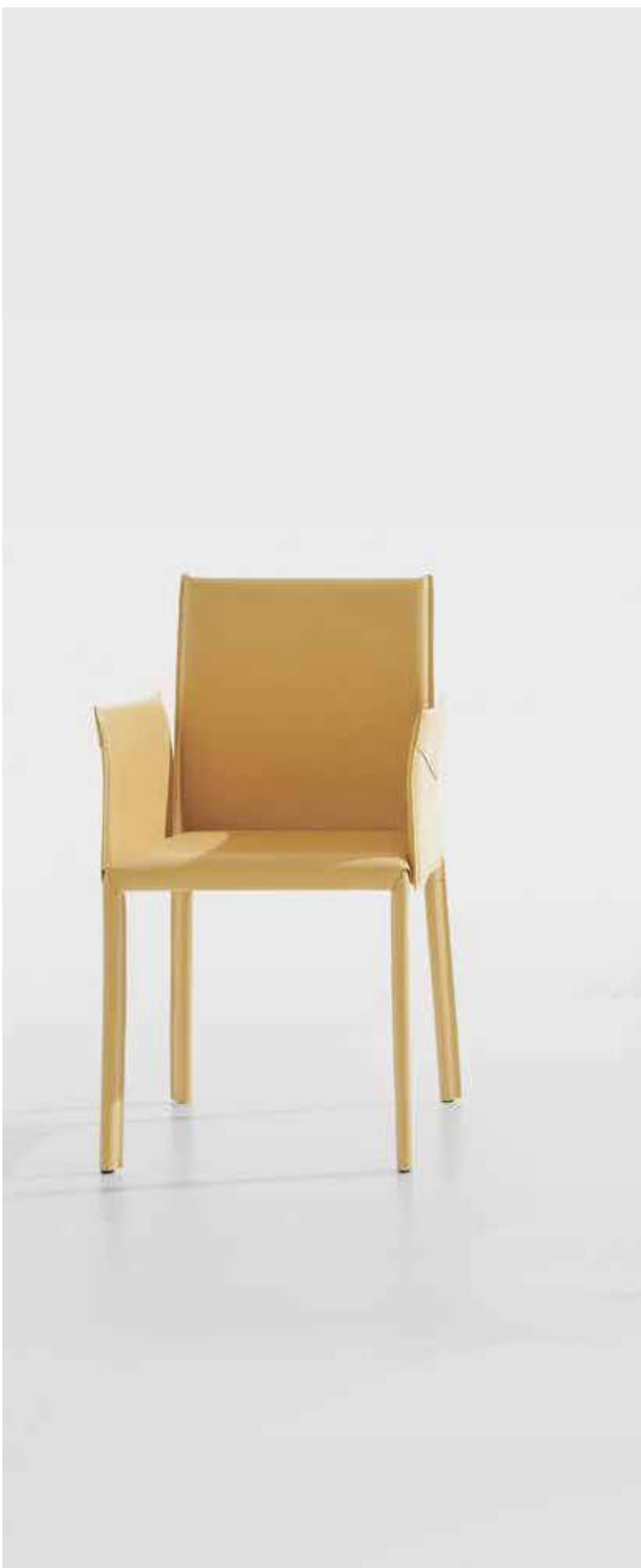



finishes

1. CU 0277 / 2-3. CU 0282 / 4. CU 0279

fuego

268



designer

Alessandro Crosera

it La curva delicata dello schienale caratterizza Fuego, seduta impilabile con struttura in tondino di metallo cromato e base a slitta.

en The delicate curving backrest makes Fuego distinctive. This stackable seat has a framework of chromed metal rods and a sled base.

fr Fuego se distingue par son dossier à la courbe délicate. Ce siège empilable possède une structure à tubes de métal chromé et un piétement traîneau.



finishes
1. MA 0803 / 2. MA 0706



finishes

1, 3. MA 0603 / 2. TA 0650 /
4. ZS 06KO / 5. ZS 03CV



finishes

6. MA 0803 / 7. MA 0706



elements



petty

it_Appendiabiti componibile a muro in plastica. *Colori:* bianco, nero.

en_Wall-mounted modular plastic coat hooks. *Colours:* white, black.

fr_Patère modulable en plastique. *Coloris :* blanc, noir.



joy

it_Appendiabiti a colonna con struttura verniciata grigia e ganci in plastica.

Colori: arancione, nero, trasparente.

en_Column-design coat stand with a grey-painted frame and plastic hooks.

Colours: orange, black, transparent.

fr_Porte-manteaux colonne à structure vernie grise et crochets en plastique.

Coloris : orange, noir, transparent.



kasta

it_Portabiti, struttura di metallo con ruote.

Colori: grigio alluminio.

en_Coat rail with a metal frame and wheels.

Colours: grey aluminium.

fr_Portant à structure en métal et à roulettes.

Coloris : gris aluminium.



L/W 150 x P/D 62 x H 161 cm

petalo

it_Appendiabiti verniciato grigio
alluminio con ganci portabiti
in plastica. *Colori:* nero, blu,
verde, arancione.

en_Coat stand in grey-painted
aluminium with plastic coat hooks.
Colours: black, blue, green, orange.

fr_Porte-manteaux verni gris aluminium
à crochets en plastique. *Coloris :* noir,
bleu, vert, orange.

**spicchio**

it_Gettacarte in metallo verniciato.

Colori: grigio, nero.

en_Wastepaper bin in painted metal.

Colours: grey, black.

fr_Corbeille en métal verni.

Coloris : gris, noir.

**basket**

it_Cestino in maglia di metallo.

Colori: grigio, nero.

en_Bin in perforated metal.

Colours: grey, black.

fr_Corbeille en maille métallique.

Coloris : gris, noir.

**pot**

it_Cestino in materiale plastico.

Colori: verde, grigio, bordeaux, nero.

en_Plastic bin. *Colours:* green, grey,
burgundy, black.

fr_Corbeille en plastique.

Coloris : vert, gris, bordeaux, noir.



elements

276

izumi

it_Tavolino da bar, alto o basso,
con piano rotondo o quadrato.

Finitura piano: HPL bianco, nero,
rosso. *Finitura struttura:* metallo
cromato, verniciato bianco, nero, rosso.

en_Bar table, high or low, with round
or square top. *Top finish:* white, black or
red HPL. *Frame finish:* chromed metal,
white, black or red powder coated.

fr_Table de bar, version basse ou
mange-debout, plateau rond ou
carré. *Finition plateau :* HPL blanc,
noir, rouge. *Finition piétement :* métal
chromé ou verni blanc, noir, rouge.

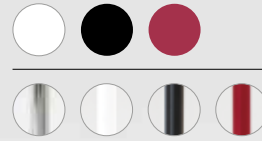

L/W 69 x P/D 69 x H 75 cm

L/W 69 x P/D 69 x H 106 cm

Ø 69 x H 75 cm

Ø 69 x H 106 cm



slim

it Tavolo con ruote con piano ribaltabile verticalmente. *Finitura piano*: melaminico bianco, nero. *Finitura struttura*: metallo cromato, verniciato nero.

en Swivel table with vertically folding top. *Top finish*: white or black melamine. *Frame finish*: black powder coated or chromed metal.

fr Table à roulettes et plateau pliant verticalement. *Finition plateau*: mélaminé blanc, noir. *Finition piètement*: métal chromé ou verni noir.



L/W 160 x P/D 80 x H 73 cm

L/W 140 x P/D 80 x H 73 cm



twist

it_Tavolino con piano quadrato o rettangolare. *Finitura piano:* vetro acidato bianco. *Finitura struttura:* acciaio inox, gambe cromate.

en_Coffee table with square or rectangular top. *Top finish:* white etched glass. *Frame finish:* stainless steel.

fr_Table à plateau carré ou rectangulaire. *Finition plateau :* verre dépoli blanc. *Finition piétement :* acier inox.



L/W 80 x P/D 80 x H 30 cm
L/W 120 x P/D 60 x H 30 cm

only

it_Tavolino con piano quadrato o rettangolare. *Finitura piano:* vetro trasparente. *Finitura struttura:* metallo cromato.

en_Coffee table with square or rectangular top. *Top finish:* clear glass. *Frame finish:* chromed or anthracite powder coated metal.

fr_Table à plateau carré ou rectangulaire. *Finition plateau :* verre transparent. *Finition piétement :* métal chromé ou verni anthracite.



L/W 61 x P/D 61 x H 43 cm
L/W 100 x P/D 61 x H 43 cm



tommy

it_Tavolino con piano quadrato o rettangolare. *Finitura piano*: vetro acidato. *Finitura struttura*: metallo cromato, verniciato nero.

en_Coffee table with square or rectangular top. *Top finish*: etched glass. *Frame finish*: chromed or black powder coated metal.

fr_Table à plateau carré ou rectangulaire. *Finition plateau*: verre acidé. *Finition piétement*: métal chromé ou verni noir.



L/W 50 x P/D 50 x H 35 cm

L/W 90 x P/D 50 x H 35 cm



elements

280

rock

designer Alessandro Crosera

it_Tavolino per l'attesa, alto o basso,
con piano quadrato. *Finitura piano:*
melaminico bianco, tortora, rovere.

Finitura struttura: metallo cromato,
verniciato bianco.

en_Waiting area table, in high or low
version, with square top. *Top finish:*
white, taupe or oak melamine.

Frame finish: white powder coated
or chromed metal.

fr_Table pour salles d'attente, version
basse ou haute, plateau carré.

Finition plateau : mélaminé blanc, gris
tourterelle, chêne. *Finition piétement :*
métal chromé ou verni blanc.



L/W 63 x P/D 63 x H 30 cm

L/W 43 x P/D 43 x H 45 cm



round

designer Alessandro Crosera

it Tavolino per l'attesa, alto o basso,

con piano rotondo. *Finitura piano:*

melaminico bianco, tortora, rovere.

Finitura struttura: metallo cromato,

verniciato bianco.

en Waiting area table, in high or

low version, with round top. *Top*

finish: white, taupe or oak melamine.

Frame finish: white powder coated

or chromed metal.

fr Table pour salles d'attente, version

basse ou haute, plateau rond. *Finition*

plateau : mélaminé blanc, gris

tourterelle, chêne. *Finition piétement :*

métal chromé ou verni blanc.



Ø 63 x H 30 cm

Ø 43 x H 45 cm



elements

282

sound

designer Alessandro Crosera

it_ Tavolino polifunzionale con piano sagomato. *Finitura piano:* MDF laccato bianco, laminato rovere. *Finitura struttura:* metallo verniciato bianco.

en_ Multifunctional coffee table with carved MDF top. *Top finish:* white lacquered or laminated oak. *Frame finish:* white powder coated metal.

fr_ Table multifonctions à plateau profilé. *Finition plateau :* MDF laqué blanc, stratifié chêne. *Finition piètement :* métal verni blanc.



L/W 28 x P/D 40 x H 69 cm



cloud

it_Serie di cuscini disponibili
in tinta unita o in fantasia.

en_Series of cushions available
in solid colours or patterned fabric.

fr_Série de coussins à coloris uni
ou fantaisie.

L/W 47 x P/D 47 cm

283

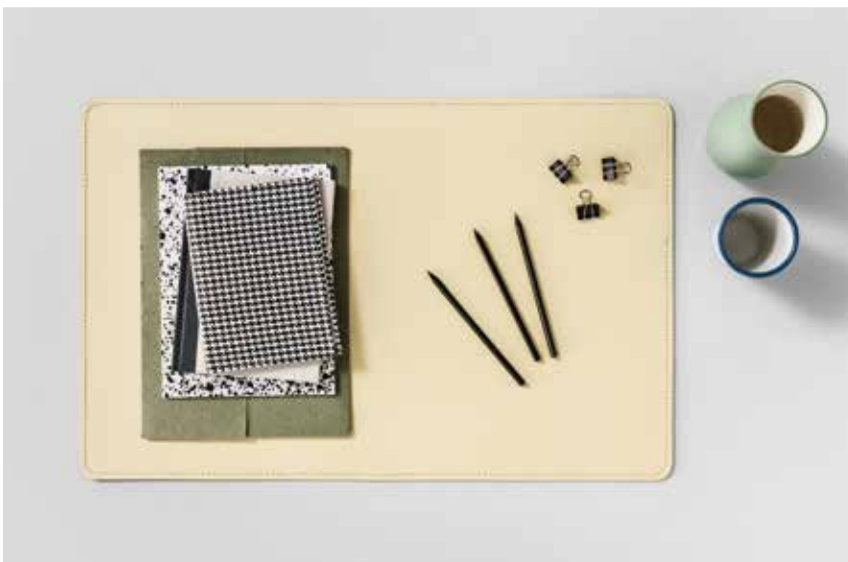

louise

it_Sottomani per scrivania,
disponibili in vari rivestimenti.

en_Desk pad, available
in multiple finishes.

fr_Sous mains pour bureau,
disponibles en plusieurs finitions.

L/W 70 x P/D 45 cm



LA NATURALE
PERFEZIONE
STRAORDINARIA

NATURE IS
EXTRAORDINARY
PERFECTION

finishes

cartella colori essential

286

CM

Rete
Mesh
Résille

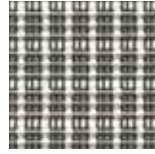

0600

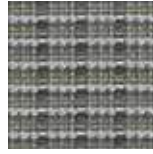

0800

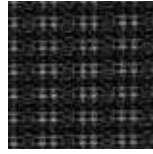

0900



0700

CU

Cuoio rigenerato
Recycled bonded leather
Cuir reconstitué



0275



0284



0271



0278



0274



0279



0282



0273



0277



0276



0272

CX

Tessuto riciclabile
ignifugo Classe 1
Recyclable fire-
retardant fabric
Tissu recyclable
ignifuge

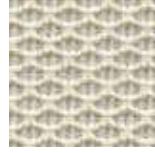

0120



0110

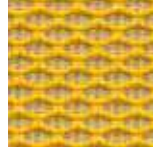

0210



0353

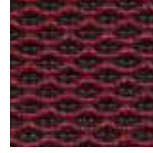

0390



0570



0880



0925



0655



0942



0971



0999



0523



0575



0915

GO

Rete a maglia
Mesh
Maille



0001



0029

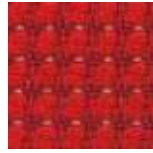

0008



0041

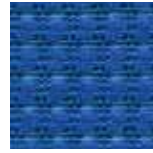

0015



0033

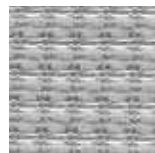

0043



0089

KT

Tessuto autoportante
Supportive fabric
Tissu autoportant



0021

0022

0090

0060

0080

0011

LN

Pelle fiore
Full-grain leather
Cuir pleine fleur



2000

2200

5432

3396

2523

3348



6400



6688



2511



2535

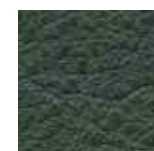

0837



2527



0632



5478



7701



7704



6644



0443

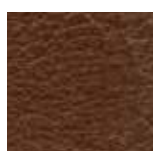

3364



2557

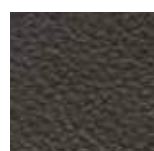

2500



1000

LX

Pelle smerigliata
Corrected grain leather
Cuir rectifié



0018

0013

0011

0026

0017

MA

Finta pelle ignifuga Classe 1
Fire-retardant artificial leather
Similicuir ignifuge



0100

0102

0607

0804

0300

0304

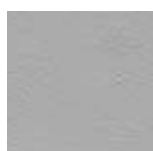

0603



0901



0706



0803



0403



0200

cartella colori essential

288

MI

Tessuto ignifugo Classe 1
Fire-retardant fabric
Tissu ignifuge M1

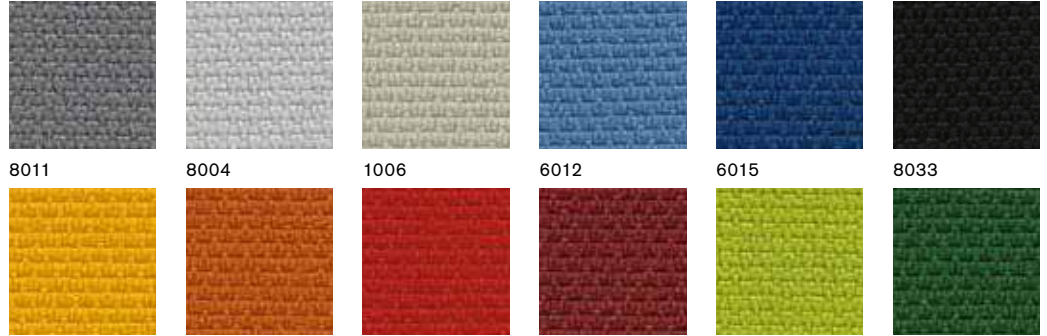

8011 8004 1006 6012 6015 8033
3008 4030 4028 4003 7022 7007

ML

Tessuto ignifugo
Fire-retardant fabric
Tissu ignifuge



0022 0035 0034 0025 0024 0036
0008 0013 0014 0010 0002 0016
0007

NB

Pelle + poliestere effetto nabuk
Leather + polyester nubuck finish
Cuir + polyester aspect nubuck



0013 0011 0010 0028

NE

Tessuto ignifugo Classe 1
Fire-retardant fabric
Tissu ignifuge M1



0532 0533 0534 0119 0053 0012
0120 0572 0013 0236 0234 0173

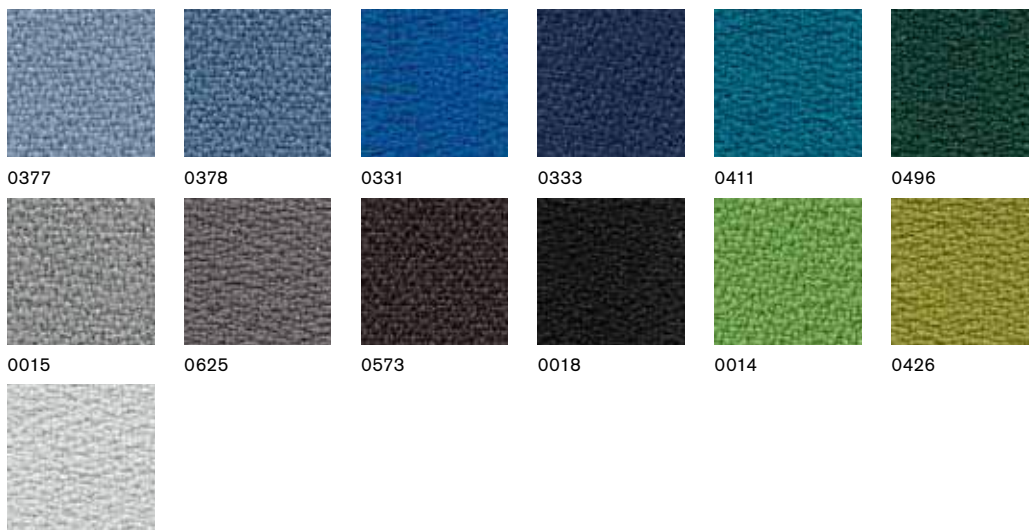

0377

0378

0331

0333

0411

0496



0015



0625



0573



0018



0014

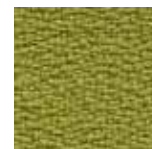

0426



0643

RC

Tessuto ignifugo Classe 1
Fire-retardant fabric
Tissu ignifuge M1



8501



7504



7502

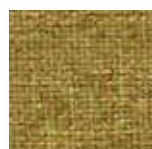

3508

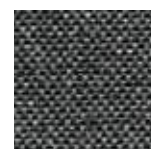

8030



2504



6501



6503

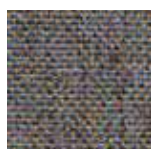

6508



3503

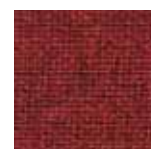

4504



5501



1501

RT

Rete
Mesh
Résilie

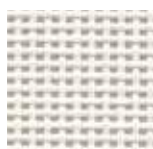

0014

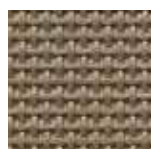

0022

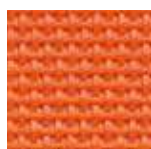

0025



0020



0021

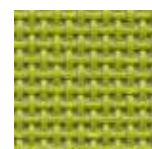

0023

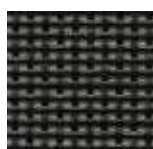

0015



0024

cartella colori essential

290

TA

Tessuto ignifugo
Fire-retardant fabric
Tissu ignifuge



TF

Finta pelle ignifuga Classe 1
Fire-retardant artificial leather
Similicuir ignifuge

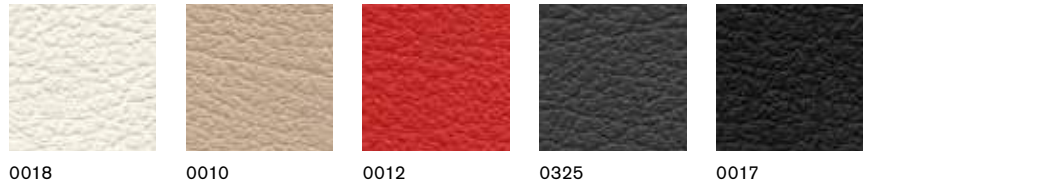

WM

Tessuto lana ignifugo
Fire-retardant wool fabric
Tissu laine ignifuge

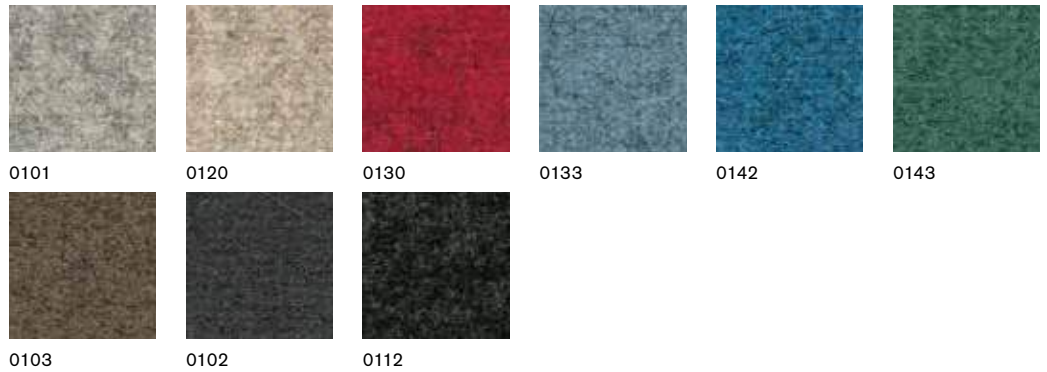

ZS

Finta pelle ignifuga Classe 1
Fire-retardant artificial leather
Similicuir ignifuge



PXB

Plastiche Blend
Blend plastics
Plastiques Blend

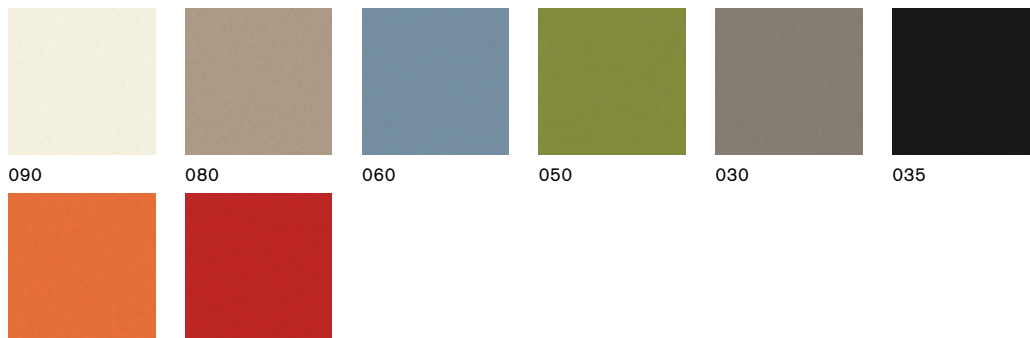

090

080

060

050

030

035

081

082

PXC

Plastiche Clark e Lois
Clark and Lois plastics
Plastiques Clark et Lois

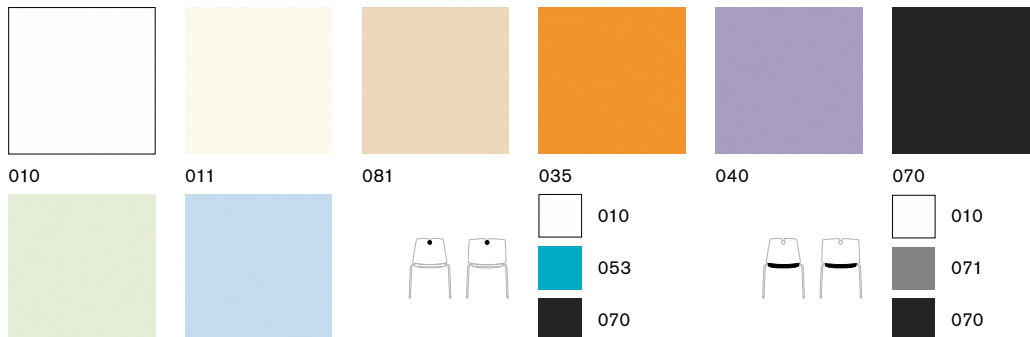

010

011

081

035

040

070

063

052

010

053

070

010

071

070

PXD

Plastiche Dolly
Dolly plastics
Plastiques Dolly



090

011

051

070

071

031

PXR

Plastiche Role
Role plastics
Plastiques Role



072

030

035

020

062

050

PXV

Plastiche Voilà
Voilà plastics
Plastiques Voilà



033

032

031

034

PXW

Plastiche Wendy
Wendy plastics
Plastiques Wendy



046

043

044

042

045

041



048

cartella colori special

292

AB



0003



0001

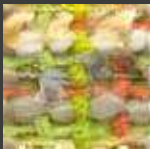

0002

BALANI



0985



0970



0122



0223



0556



0906

CORTEZ

Rubelli

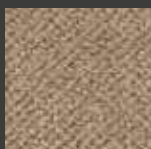

0004

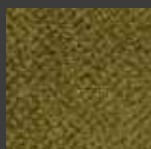

0016



0012

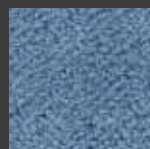

0011



0013

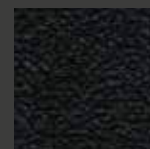

0010



0020

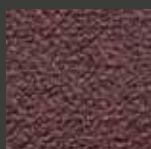

0024

ML STRIPE



0002



0004



0006



0007

RIME

Kvadrat



0621 0731 0721 0781 0641 0471

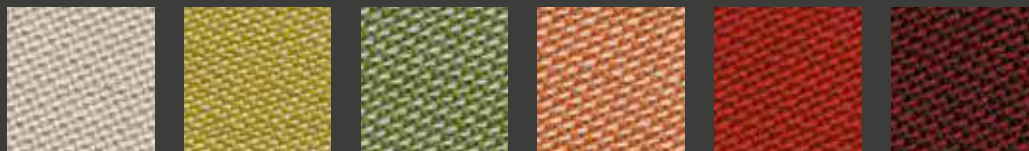

0111 0911 0921 0521 0551 0591

REMIX 2

Kvadrat

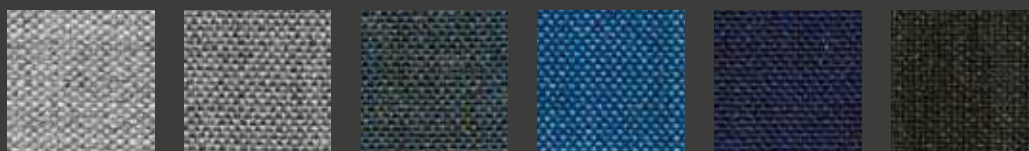

0123 0133 0753 0762 0773 0973

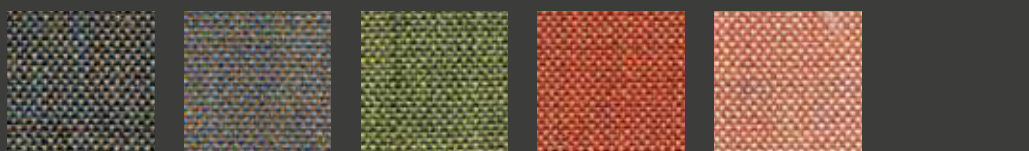

0852 0722 0933 0632 0612

SK



0854 0197 0691 0250 0229 0329



0692 0778 0779 0855 0842

WABI

Rubelli

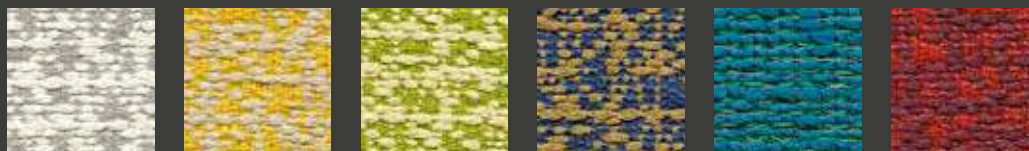

2506 2508 2512 2510 2623 2509

Baldanzi & Novelli

nordic → p. 16, 116

it_Dopo la laurea in Disegno Industriale all'ISIA di Firenze, iniziano la loro avventura progettuale. In trent'anni di esperienza hanno maturato una grande cultura progettuale, al punto da essere considerati dalle aziende più dei partner che dei designer. La loro attività parte in Italia, con la fondazione dell'azienda Casamania, si estende in Europa e oggi sono richiesti in tutto il mondo. La loro terra è frutto di continua ispirazione, le esperienze internazionali di arricchimento costante.

en_Their adventure in planning and design began after graduating from the Higher Institute for Artistic Industries (ISIA) in Florence. Over thirty years, they have acquired such an impressive design culture that they are considered partners rather than designers by the companies they work with. Their career began in Italy, where they founded the company Casamania, before expanding into Europe and worldwide, where their services are increasingly requested. Their land of origin is an inexhaustible source of inspiration, while their international experience offers opportunities for constant improvement.

fr_Après s'être diplômés en Design Industriel à l'ISIA de Florence, ils se lancent dans l'aventure de la conception. En trente ans d'expérience, ils ont acquis une grande culture du projet à tel point que les entreprises les considèrent plus comme des partenaires que comme des designers. Leur carrière débute en Italie, avec la fondation de l'entreprise Casamania, puis se développe en Europe, jusqu'à conquérir le monde entier. Leur terre est une source d'inspiration inépuisable et leurs expériences internationales un moyen d'enrichissement permanent.

C/B Design

nuvola → p. 122

fungus → p. 212

it_C/B Design è uno studio di riconosciuta fama internazionale, attivo nei diversi campi della progettazione, dal design all'architettura. Collabora con aziende leader a livello mondiale. Molti progetti hanno ricevuto prestigiosi premi internazionali, tra cui: Red Dot, IF e Good Design Award. L'attitudine all'entusiasmo, la curiosità, l'ottimismo, una particolare sensibilità per

l'innovazione tecnologica e le nuove dinamiche del mercato contemporaneo sono riconoscibili nei diversi progetti e nel metodo di lavoro dello studio.

en_C/B Design, a studio of international renown, operates in the various fields of planning, from design to architecture, working with leading international companies. A number of projects have received prestigious international awards, including Red Dot, IF and Good Design Award. An aptitude for enthusiasm, curiosity and optimism, as well as a sharp instinct for technological innovation and the new dynamics of the contemporary market are evident in the various projects and the working approach of the studio.

fr_C/B Design est un studio reconnu à l'international, actif dans différents domaines de la conception, du design à l'architecture. Il collabore avec des entreprises leaders dans le monde. Nombreux sont leurs projets qui ont remporté de prestigieux prix internationaux, parmi lesquels : Red Dot, IF et Good Design Award. La propension à l'enthousiasme, la curiosité, l'optimisme, une certaine sensibilité pour l'innovation technologique et pour les nouvelles dynamiques du marché contemporain sont tangibles dans les différents projets et dans la méthode de travail du studio.

Massimo Costaglia

tam → p. 74

Massimo Costaglia + Giulio Mazzanti

loop → p. 82

it_Massimo Costaglia è nato nel 1970 in provincia di Padova dove vive e lavora. Dopo aver conseguito il diploma all'Istituto Tecnico Industriale collabora per alcuni anni con importanti aziende italiane nel settore dell'arredo prima di fondare, nel 2001, lo studio di design che porta il suo nome. Lo studio è composto da un team esperto e qualificato con una lunga esperienza professionale nel settore di mobili per l'ufficio. Giulio Mazzanti nasce nel 1988 in provincia di Ancona dove segue la prima parte della sua formazione. Dopo aver conseguito il diploma al Liceo Artistico prosegue gli studi presso lo IUAV a San Marino e poi a Venezia. Nell'aprile 2013 consegue la laurea in Disegno Industriale del prodotto. Nel 2014 Giulio Mazzanti, dopo un tirocinio presso lo studio Massimo Costaglia Design, diventa parte integrante del Design Team.

en_Massimo Costaglia was born in 1970 in the province of Padua, where he lives and works. After gaining a Diploma from the Industrial Technical Institute, he worked for a number of years with leading Italian companies in the furnishing sector, before founding the design studio that bears his name, in 2001. The studio is made up of an expert, qualified team with lengthy professional experience in the office furnishing sector.

Giulio Mazzanti was born in 1988, in the province of Ancona, where he completed the first part of his training. After obtaining a High School Diploma in Art, he continued his studies at the Higher Institute of Architecture of Venice, first in San Marino and then in Venice. In April 2013, he graduated in Industrial Product Design. In 2014, after a period of training at Massimo Costaglia Design studio, Mazzanti became an integral part of the Design Team.

fr Massimo Costaglia est né en 1970, près de Padoue, où il habite et travaille. Après avoir obtenu son diplôme du lycée technique industriel, il collabore pendant plusieurs années avec d'importantes entreprises italiennes du secteur de l'ameublement, avant de fonder en 2001 le studio de design qui porte son nom, et qui vante aujourd'hui une équipe d'experts qualifiés ayant une longue expérience dans le secteur des meubles de bureau.

Giulio Mazzanti nait en 1988 près d'Ancône, où il suit la première partie de sa formation. Après l'obtention de son diplôme du lycée artistique, il poursuit ses études à l'IUAV, d'abord au siège de Saint-Marin, puis à Venise. En avril 2013, il obtient sa licence de Design produit industriel. En 2014, Giulio Mazzanti, après un stage auprès du studio Massimo Costaglia Design, y intègre l'équipe de designers.

Alessandro Crosera

andy → p. 62

people → p. 132

shock → p. 144

cocktail → p. 148

nesis → p. 152

nesis chic → p. 156

handle office → p. 160

block → p. 164

tulip → p. 194

patch work → p. 200

terre → p. 208

colette → p. 218

fuego → p. 268

rock → p. 280

round → p. 281

sound → p. 282

it Si laurea nel 2000 in Architettura allo IUAV di Venezia. Nel 2002 inaugura a Treviso lo studio DesignX dove si occupa di interior design e progetti di industrial design, creando collezioni di lampade, sedute e complementi d'arredo. Riceve incarichi di collaborazione per seguire molteplici progetti fino alla loro realizzazione finale, curandone anche le fasi di industrializzazione.

en Crosera graduated in 2000 from the Higher Institute of Architecture of Venice. In 2002, he opened the DesignX studio in Treviso, where he takes care of interior design and industrial design projects, creating collections of lamps, seating and furniture accessories. He is entrusted with working on numerous projects through to completion, and also takes care of the product engineering stages.

fr Diplômé en Architecture à l'IUAV de Venise, en 2000, il ouvre à Trévise, en 2002, son studio DesignX dans lequel il conçoit des projets de design industriel et de décoration d'intérieur, en créant des collections de lampes, de sièges et de compléments d'ameublement. Il collabore dans le cadre de nombreux projets, jusqu'à leur réalisation, et s'occupe également des étapes d'industrialisation.

Orlandini Design

mirò → p. 180

clark → p. 228

lois → p. 236

it Lo studio nasce 1968, anno in cui Paolo Orlandini inizia la collaborazione con Roberto Lucci. Dal 2010, insieme al figlio Folco e in collaborazione con un giovane team di designer, continua l'attività come Orlandini Design.

La lunga esperienza nel campo del design industriale si fonde con l'interesse per i trend attuali e le tecnologie più innovative. La cifra stilistica dello studio è la pulizia formale e la progettazione di soluzioni tecniche che rendono i prodotti economici e affidabili, mantenendo l'attenzione ai problemi di produzione.

en The studio was founded in 1968, the year in which Paolo Orlandini began working with Roberto Lucci. Since 2010, together with his son Folco and in collaboration with a young team of designers, the business has continued under the name of Orlandini Design, teaming the lengthy experience in the field of industrial design with an interest in current trends and the most innovative technologies. The style hallmark of the studio are its clean-cut shapes and ability to design technical solutions that guarantee affordable, reliable products, while keeping a careful eye on production issues.

fr Le studio nait en 1968, année au cours de laquelle Paolo Orlandini commence sa collaboration avec Roberto Lucci. Depuis 2010, aux côtés de son fils Folco et d'une équipe de jeunes designers, il continue son activité sous le nom de Orlandini Design. Sa longue expérience dans le domaine du design industriel se mêle à l'intérêt pour les tendances actuelles et les technologies de pointe. Le studio se démarque pour son style minimaliste et la conception de solutions techniques qui rendent les produits fiables et économiques, en gardant l'attention sur les problèmes de production.

Concept

dogtrot

Creative and design direction

Margherita Rui

Dogtrot team

Art direction

Valentina Cinetto

Graphic design

Jessica Bozza

Copywriting

Irene Samassa

Project, set design

Katia Menegaldo

Project coordinator

Giacomo Sanders

Photos

Concept image

dogtrot

Photography

Cristina Galliena Bohman

Renai&Renai

Styling

Luigina Pilloni

Laura Pasqualato

Still life

Varianti

Renai&Renai

Colour separation and print

Lucegroup

December 2017

Thanks to

ARTEMIDE, AUTHENTIC MODELS,
A+A LAB, BITOSSI, KRISTINA DAM
STUDIO, CORAXART, DANESE,
DCW ÉDITIONS, FERM LIVING,
FLOS, FRITZ HANSEN, HAY, HOUSE
DOCTOR, KOSE MILANO, JÉRÉMIE
DUPREY, LEUCOS, LOUIS POULSEN,
LA FABRIQUE À LETTRES, MILESI,
MONOGRAPH, MUUBS, NAVA,
NICOLAS VAHÉ.

ESSE SOLUTION_{S A G L}

FORNITURE AZIENDALI

Via Rompada, 37 - CASLANO

+41 076 758 5368 +41 079 709 8354

www.essesolution.ch info@essesolution.ch

adalia → p. 204
andy → p. 62
blend → p. 258
block → p. 164
celine → p. 40
clark → p. 228
cocktail → p. 148
colette → p. 218
daisy → p. 168
dolly → p. 248
ellipse → p. 196
five → p. 110
flo → p. 106
fuego → p. 268
fungus → p. 212
genesis → p. 176
handle office → p. 160
lex → p. 88
lex presidenziale → p. 58
lilliè → p. 190
loop → p. 82
lois → p. 236
mirò → p. 180
nesis → p. 152
nesis chic → p. 156
nordic → p. 16, 116
nuvola → p. 122
olite → p. 34
only → p. 172
patch work → p. 200
people → p. 132
rang → p. 68
role → p. 254
sally → p. 66
shock → p. 144
sky mesh → p. 48
sky soft → p. 48
sky ten → p. 48
tam → p. 74
terre → p. 208
time → p. 266
tulip → p. 194
venice → p. 262
voilà → p. 222
wendy → p. 242
x-chair → p. 24
zed → p. 100